

Speedway Assembly



A. Insert Track and Car Assembly.

Step 1. Click File Menu > New, click **Assembly** and OK.

Step 2. Click **Keep Visible**  in the Property Manager, **Fig. 1**.

Step 3. Click **Browse** in the Property Manager, **Fig. 1**.

Step 4. Select your **TRACK** file and click Open.

Step 5. Click OK  in the Property Manager. This will place the Track origin at the assembly origin and fix the position of the Track so that it cannot move. This fixed component should have a **(f)** before its name in the Feature Manager  (f) TRACK<1>.

Step 6. Click **Browse** in the Property Manager, **Fig. 1**.

Step 7. Select your **CAR ASSEMBLY** file and click Open. You might have to change **Files of Type** to **All Files** to view the assembly file.

Step 8. Click approximately where the **Car Assembly** is positioned in **Fig. 2**.

Step 9. Click OK  in the Property Manager when done.

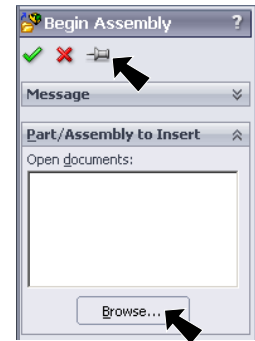
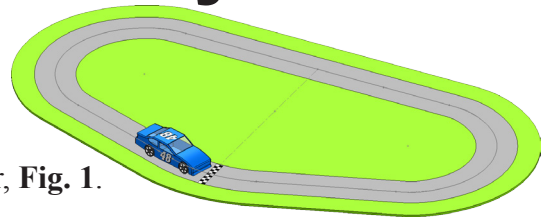

Fig. 1

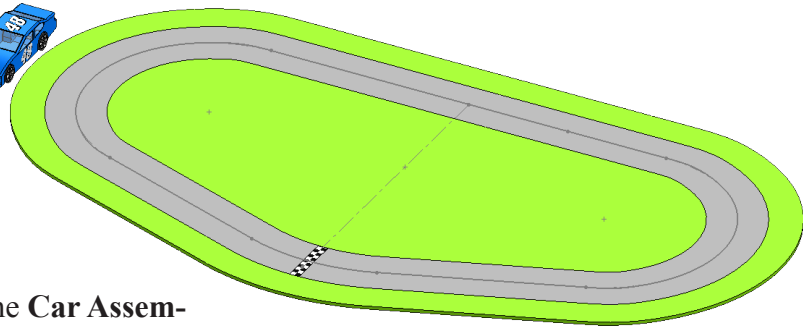

Fig. 2

B. Save as "SPEEDWAY".

Step 1. Click File Menu > Save As.

Step 2. Key-in **SPEEDWAY** for the filename and press ENTER.

C. Mate: Wheels and Track.

Step 1. Zoom in around **Car Assembly**, **Fig. 3**. To **zoom**, hold down **Shift** key and drag with middle mouse button (wheel). To **pan**, hold down **Ctrl** key and drag with middle mouse button (wheel).



Zoom

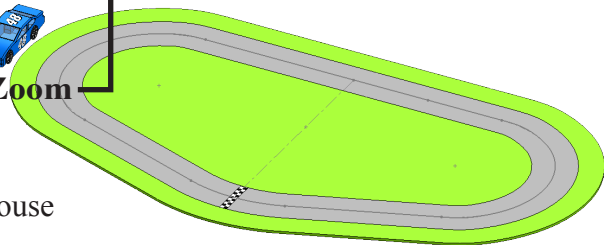

Fig. 3



Step 2. Click **Filter Faces**  (X) on the **Selection Filter toolbar** at the bottom of the display, **Fig. 4**. If necessary, use **F5** key to display the toolbar.



Fig. 4

Step 3. Click **Mate**  on the Assembly toolbar.

Step 4. Click **cylindrical face front Wheel** and **top face of Track**, **Fig. 5**.

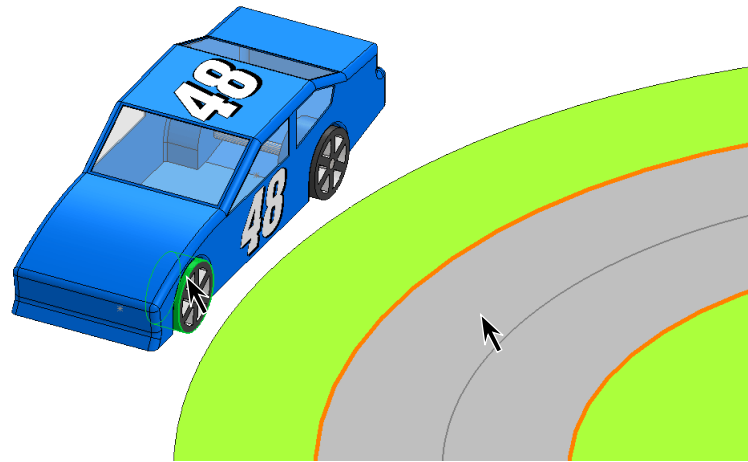

Fig. 5



Step 5. Click **Add/Finish Mate**  in Mate pop-up toolbar to add a **Tangent** mate, **Fig. 6**.



Fig. 6

Step 6. Click **cylindrical face rear Wheel** and **top face of Track**, **Fig. 7**.
If necessary, pan down to Car Assembly. To **pan**, hold down **Ctrl** key and drag with middle mouse button (wheel).

Step 7. Click **Add/Finish Mate**  in Mate pop-up toolbar to add a **Tangent** mate.

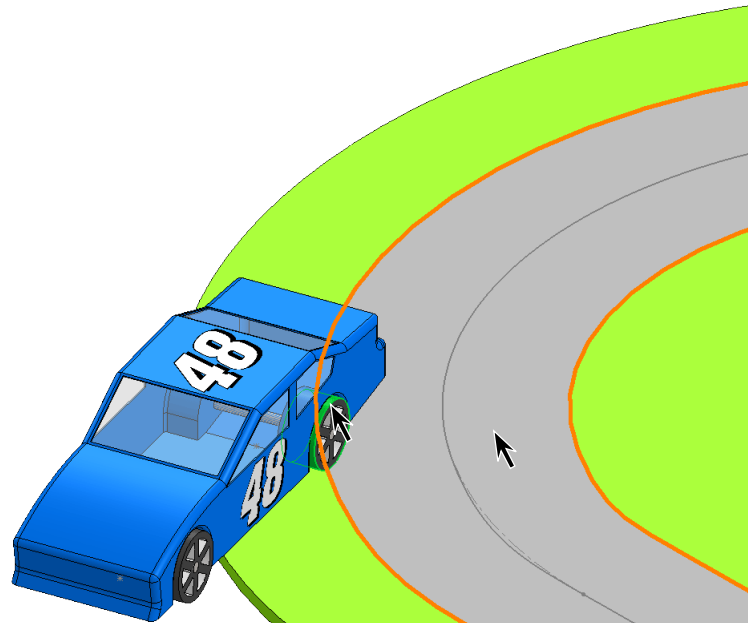

Fig. 7

Step 8. Click **Filter Faces**  (X) to **turn OFF** on the **Selection Filter toolbar** at the bottom of the display, **Fig. 8**. If necessary, use **F5** key to display the toolbar.



Fig. 8

D. Path Mate: Tow Point and Fit Spline Path.

Step 1. In the Mate Property Manager set:

expand **Advanced Mates**,

Fig. 9

select **Path Mate**



Step 2. Click the **TOW POINT** in the Car body and **FIT SPLINE PATH** in the Track, **Fig. 10**.

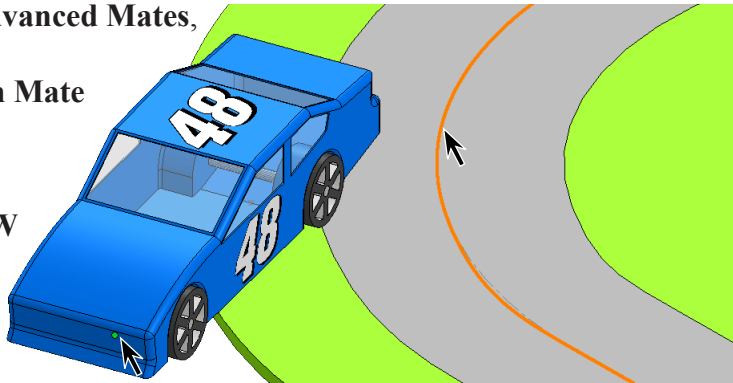



Fig. 10

Step 3. Click OK  in the Property Manager to add a **Path** mate, **Fig. 11** and **Fig. 12**.

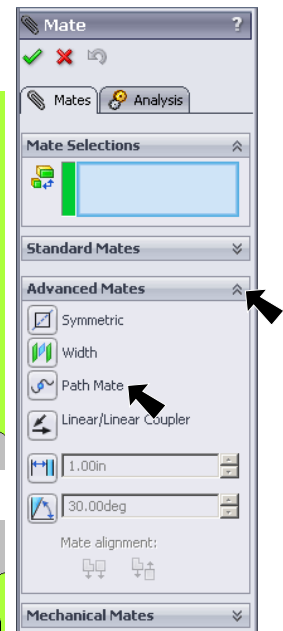

Fig. 9

E. Mate: Trail Point and Fit Spline Path.

Step 1. In the Mate Property Manager expand **Standard Mates**, **Fig. 11**.

Step 2. Click the **TRAIL POINT** in the Car body and **FIT SPLINE PATH** in the Track, **Fig. 13**.

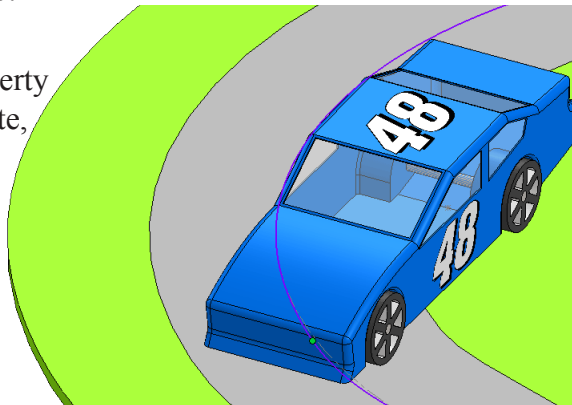



Fig. 12

Step 3. Click Add/Finish Mate  in Mate pop-up toolbar to add a **Coincident** mate, **Fig. 14** and **Fig. 15**.

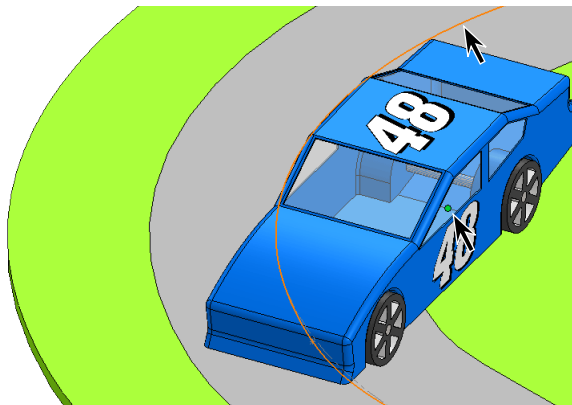

Fig. 13

Step 4. Click OK  in the Property Manager.

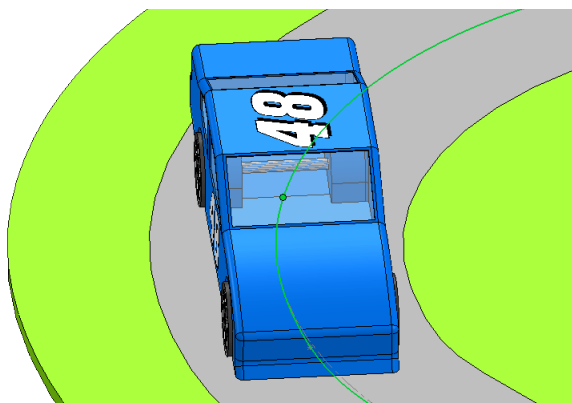

Fig. 15

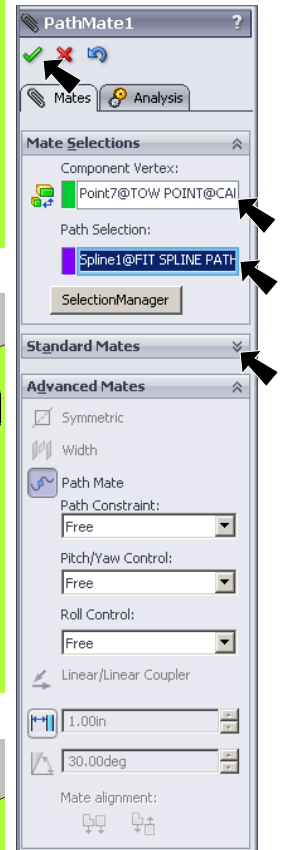

Fig. 11



Fig. 14

F. Mate: Distance.

Step 1. Zoom out to view **Car Assembly and Start/Finish line**, **Fig. 16**. To **zoom**, hold down **Shift** key and drag with middle mouse button (wheel). To **pan**, hold down **Ctrl** key and drag with middle mouse button (wheel).

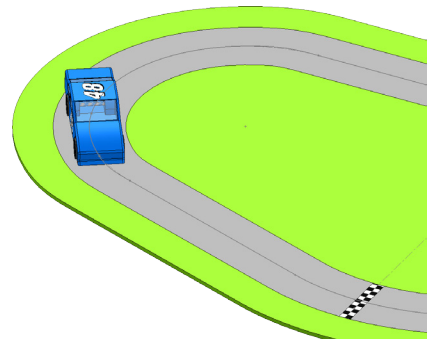

Fig. 16

Step 2. Drag car up to Start/Finish line, **Fig. 17**.

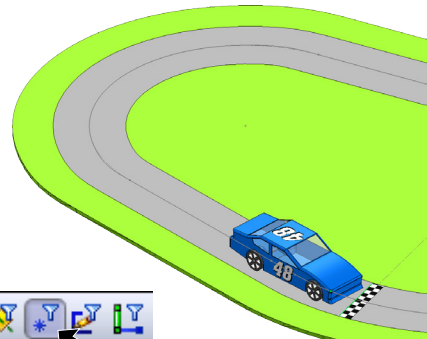



Fig. 17

Step 3. Click **Rebuild**  (**Ctrl-B**) on the Standard toolbar.

Step 4. Click **Filter Sketch Points**  on the **Selection Filter toolbar** at the bottom of the display, **Fig. 18**. If necessary, use **F5** key to display the toolbar.

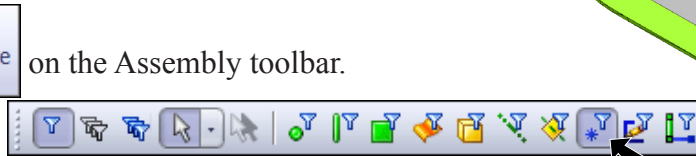

Fig. 18

Step 5. Click **Mate**  on the Assembly toolbar.

Step 6. Click the **TOW POINT** in the Car body, **Fig. 19**.

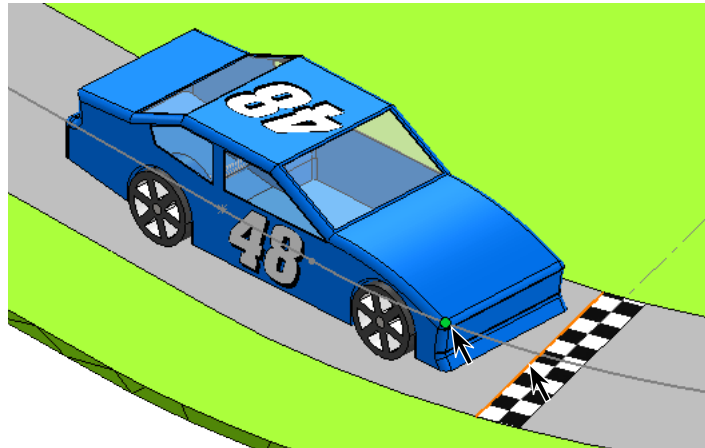

Fig. 19

Step 7. Click **Filter Sketch Points**  to **turn OFF** on the **Selection Filter toolbar** at the bottom of the display, **Fig. 20** or use **F6** key to turn off all filters.



Fig. 20

Step 8. Click the **front edge of Start/Finish line** in the Track, **Fig. 19**.



Step 9. Click **Distance**  in Mate pop-up, **Fig. 21**. Set **distance** to **1.4** and press **ENTER**. The Car should be behind the Start/Finish line, **Fig. 22**. If positioned in opposite direction, click **Flip Dimension**  in the Mate pop-up, **Fig. 21**. Click **Add/Finish Mate**  to add



Fig. 21

Distance mate.

Step 10. Click **OK**  in the Property Manager.



Fig. 22

G. Suppress Distance Mate.

Step 1. **Suppress the Distance Mate** you just created. To suppress the Mate, expand Mates in the Feature Manager, **right click Distance1 mate** and click **Suppress**  from the menu, **Fig. 23**. Later we can unsuppress this Distance mate to realign Car to start position.

Step 2. Save. Use **Ctrl-S**.

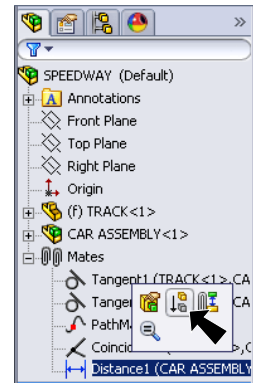

Fig. 23

