



# Chair Drawing

## A. Insert Isometric View.

Step 1. Click File Menu > New, click **Drawing** and OK.

Step 2. Click **Browse** in the Property Manager.

Step 3. Select your **CHAIR ASSEMBLY** file and click Open.

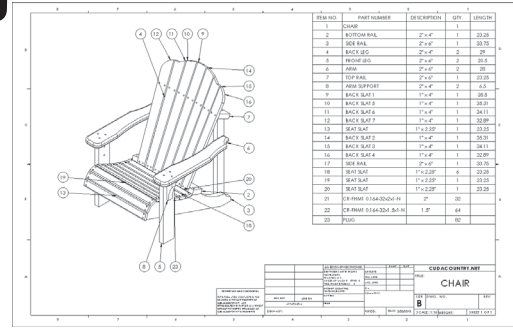

Step 4. In the Property Manager set: under Orientation, **Fig. 1**

click **Isometric**



check **Preview**

under Scale

select **Use custom scale**

select scale **1:8**

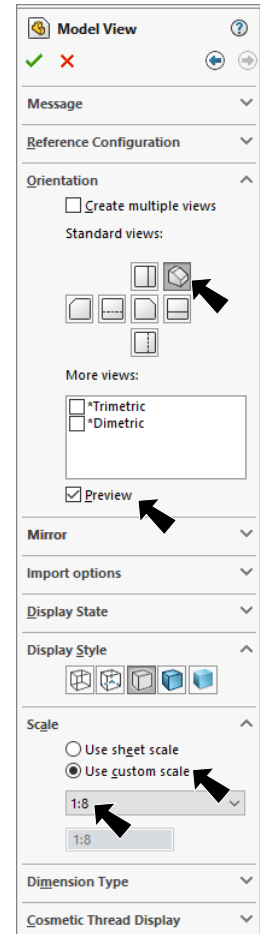

Fig. 1

Step 5. Move the cursor into the graphic area. Align the left edge of the preview with the left border line and align the top of preview with the top border line. Click to place the Isometric view, **Fig. 2**.

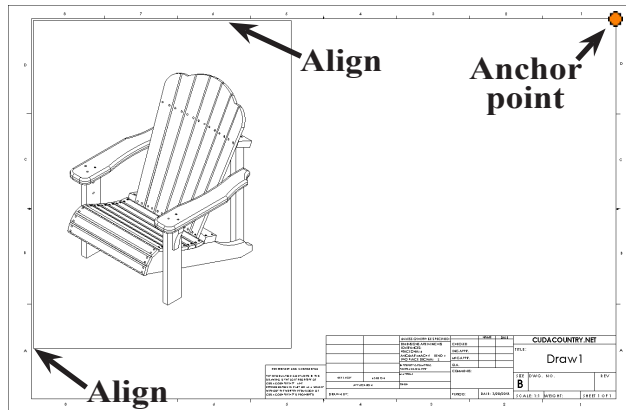

Fig. 2

Step 6. Click OK  in the Property Manager.

## B. Set Anchor.

Step 1. Expand **Sheet Format1** in the Feature Manager, **right click Bill of Materials Anchor1** and click **Set Anchor** from menu, **Fig. 3**.

Step 2. Click **top right corner** of the border lines, **Fig. 2**.

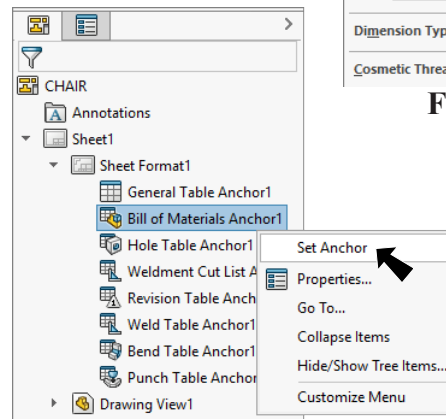

Fig. 3

## C. Save as "CHAIR".

Step 1. Click File Menu > Save As.

Step 2. Key-in **CHAIR** for the filename and press ENTER.

## D. Add Bill of Materials (BOM).

Step 1. Click Insert Menu > Tables > Bill of Materials.

Step 2. Click Chair in Isometric view, **Fig. 4**.

Step 3. In the Property Manager set under Table Template, **Fig. 5**

click **Open table template**   
select **bom-weldment cut list.sldbomtbt** from list of files and click Open, **Fig. 6**

under Table Position, **Fig. 5**  
check **Attach to anchor point**

under BOM Type  
select **Indented**  
Numbering **Flat numbering**  
check **Detailed cut list**

click OK .

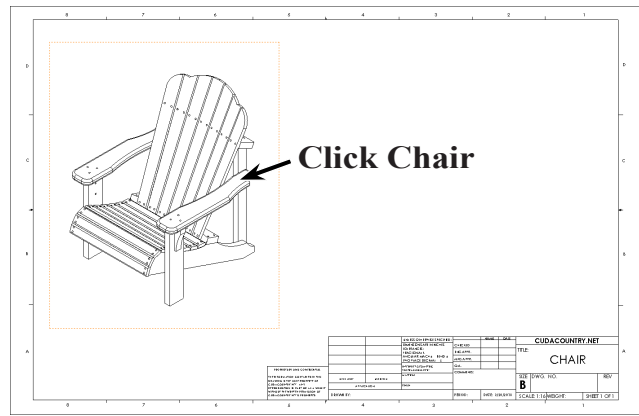

**Fig. 4**

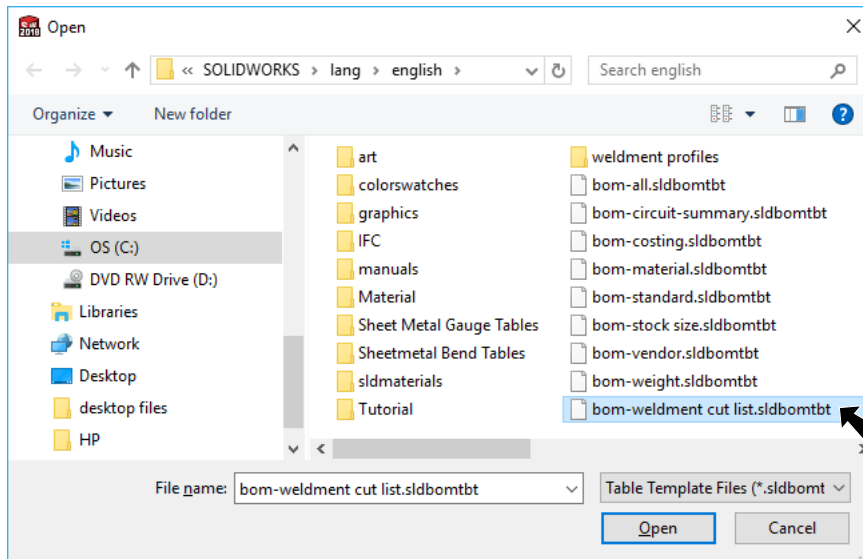

**Fig. 6**

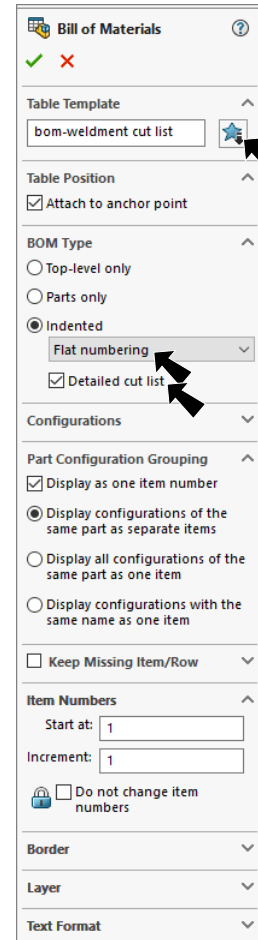

**Fig. 5**

## E. Set Stationary Corner.

Step 1. Click the **Pan**  icon in the top left corner of the table, **Fig. 7**.

Step 2. In the Bill of Material Property Manager set, under **Table Position** select **Top Right** , **Fig. 8** click OK .

Step 3. Drag the column divider to resize column. Widen the PART NUMBER to fit the Screw text on one line and shrink the DESCRIPTION down, **Fig. 9**. To resize, position cursor over column divider, when cursor changes to  drag column divider.

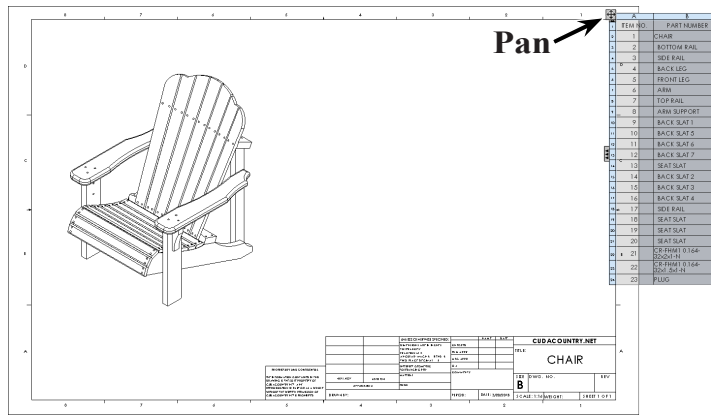

Fig. 7

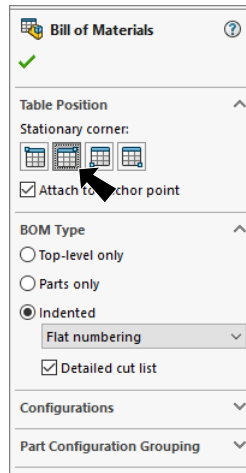

Fig. 8

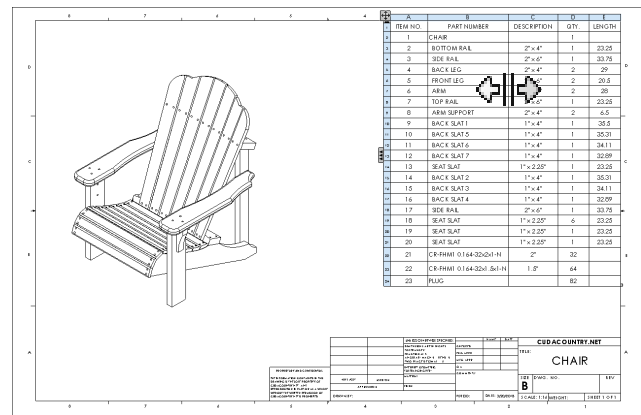
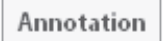
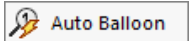



Fig. 9

## F. Auto Balloons.

Step 1. Click Chair in Isometric view on your drawing, **Fig. 10**.

Step 2. Click **Annotation**  on the Command Manager toolbar.

Step 3. Click **Auto Balloon**  on the Annotation toolbar.

Step 4. In the Property Manager, grab a Balloon and drag to size group, **Fig. 11** click OK .

Step 5. Save. Use **Ctrl-S**.

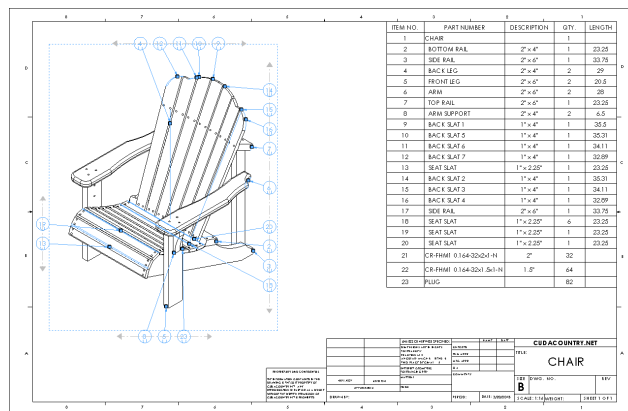

Fig. 11

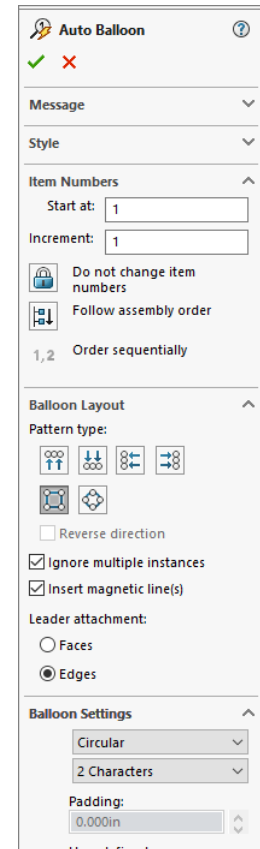

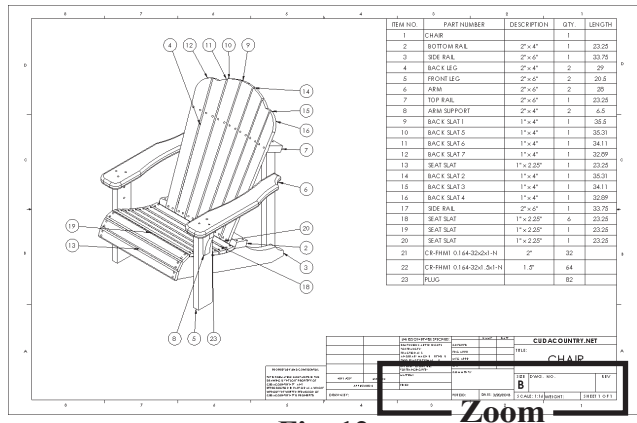

Fig. 10

## G. Add Your Name and Period to Title Block.

Step 1. Use the **Zoom to Area**  in the View toolbar to drag a zoom window around the **DRAWN BY** and **PERIOD** in the title block, **Fig. 12**.

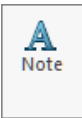

**Fig. 12**

Step 2. Click **Note**  on the Annotation toolbar.

Step 3. Click just to the right of **DRAWN BY**., **Fig. 13**.

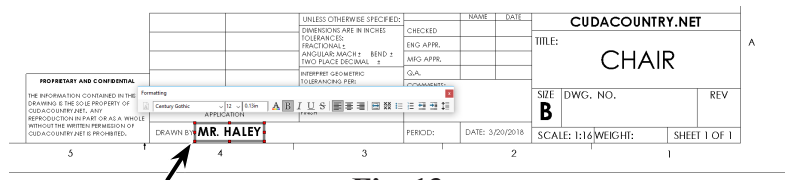

**Fig. 13**

Step 4. Lock the Caps and key-in **your first and last names**, **Fig. 12**.

Step 5. Click **OK**  in the Property Manager.

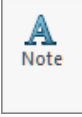
Step 6. Click **Note**  on the Annotation toolbar.

Step 7. Click just to the right of **PERIOD**., click and key-in **your Period number**, **Fig. 14**.

Step 8. Click **OK**  in the Property Manager.

Step 9. Save. Use **Ctrl-S**.

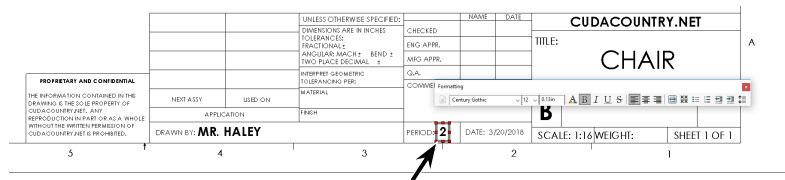

**Fig. 14**