

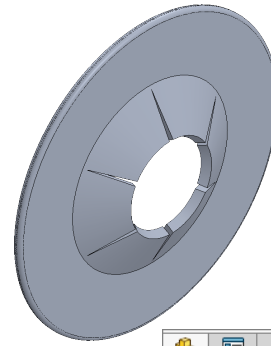

CO2 Shell Car Axle Retainer



A. Revolve Thin Feature.

Step 1. Click File Menu > New, click **Part Metric** and OK.

Step 2. Click **Front Plane**  in the Feature Manager and click **Sketch**  from the context toolbar, **Fig. 1**.

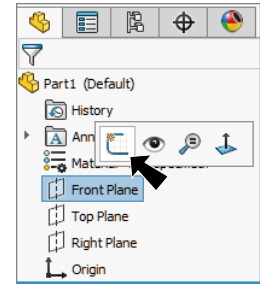





Fig. 1

Step 3. Click **Line**  (**L**) on the Sketch toolbar.

Step 4. Sketch a line starting directly above the Origin  but do not sketch the line to the Origin, **Fig. 2**. Sketch a second line from bottom endpoint of first line at angle to the right. Do not bring the angle line down to Origin.

Step 5. Click **Smart Dimension**  (**S**) on the Sketch toolbar.

Step 6. Add dimensions, **Fig. 3**.

Step 7. Click **Centerline**  in the **Line flyout**  on the Sketch toolbar.

Step 8. Sketch a **horizontal centerline** from the Origin , **Fig. 4**.

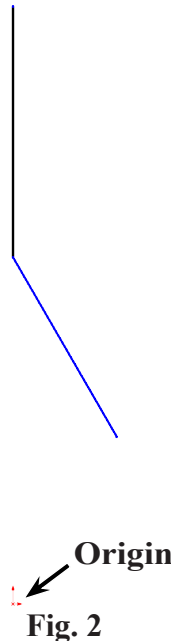

Fig. 2

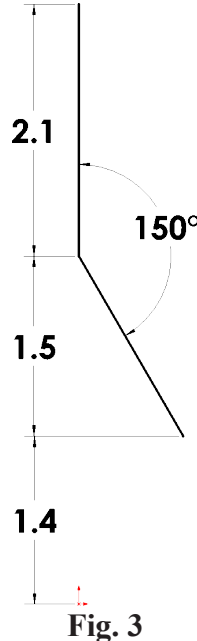

Fig. 3

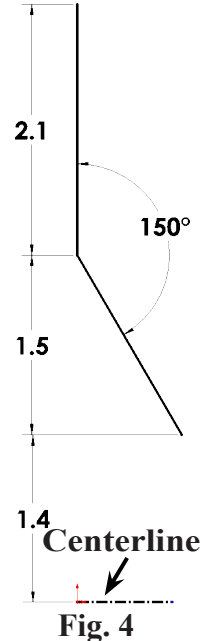



Fig. 4

Step 9. Click **Features**  on the Command Manager toolbar.

Step 10. Click **Revolved Boss/Base**  on the Features toolbar.

Step 11. Click **No** to automatically close sketch, **Fig. 5**.

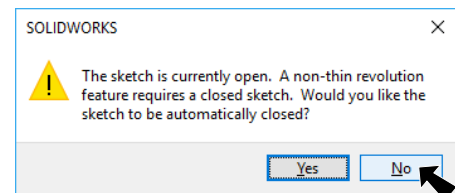

Fig. 5

Step 12. Click **Front**  on the Standard Views toolbar. (Ctrl-1)

Step 13. In the Revolve Property Manger set:
under Thin Feature, **Fig. 6**

click **Reverse direction** 

Thin feature should be to **right of sketch**, if in opposite direction, click Reverse direction, **Fig. 7**

Direction 1 Thickness  T1 .3

click OK  .

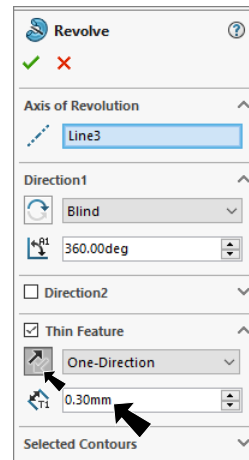

Fig. 6

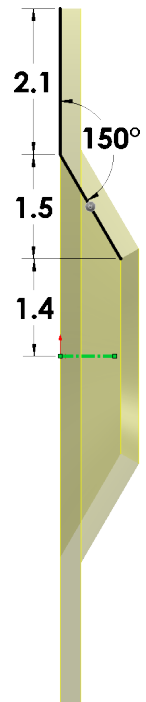

Fig. 7

B. Save as "AXLE RETAINER".



Step 1. Click File Menu > Save As.

Step 2. Key-in **AXLE RETAINER** for the filename and press ENTER.

C. Cut.

Step 1. Click **Right Plane**  in the Feature Manager and click **Sketch**  on the content toolbar, **Fig. 8**.

Step 2. Click **Left**  on the Standard Views toolbar. (Ctrl-3)

Step 3. Click **Midpoint Line**  in the **Line flyout**  on the Sketch toolbar.

Step 4. Sketch a horizontal line out from the Origin  and continue line up to edge of body and back to other endpoint of horizontal line, **Fig. 9**.

Step 5. **Right click graphics area and click Select** from menu to unselect Line tool.

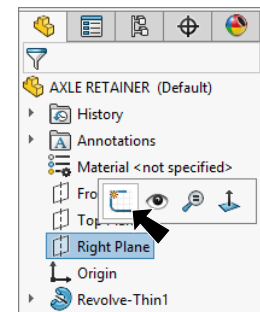

Fig. 8

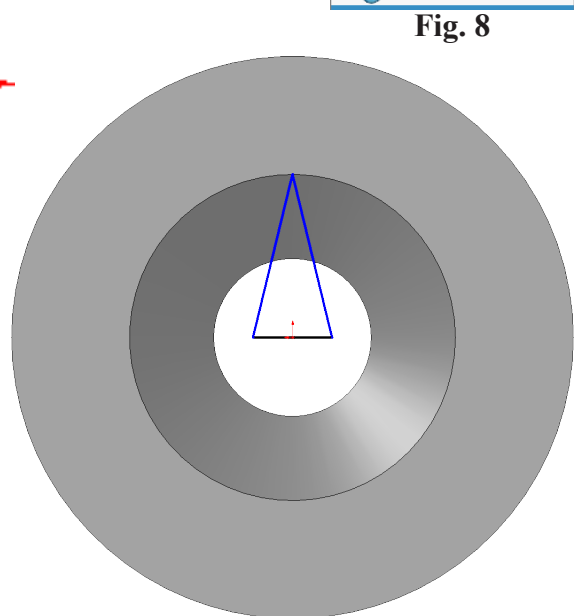



Fig. 9

Step 6. **Ctrl click top endpoint of line and Origin**  to select both. Release Ctrl key and click **Make Vertical**  on the context toolbar, **Fig. 10**.

Step 7. Click **Smart Dimension**  (S) on the Sketch toolbar.

Step 8. Dimension horizontal line **.3**, **Fig. 11**.

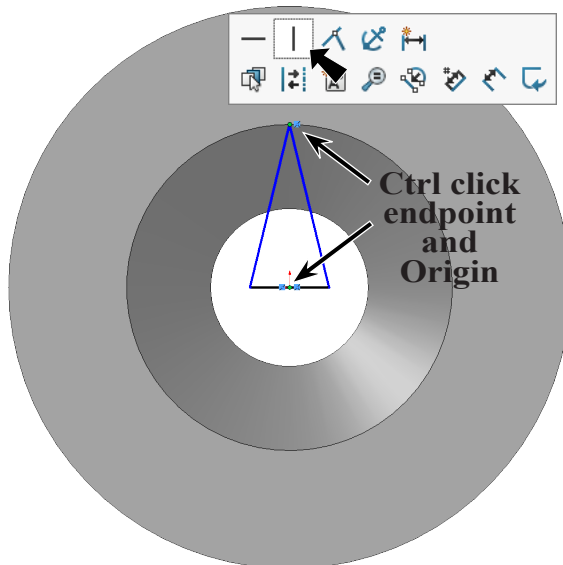

Fig. 10

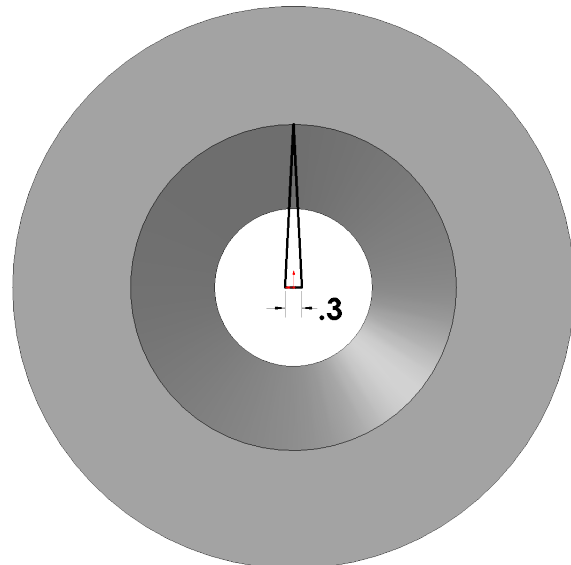

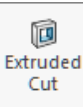



Fig. 11

Step 9. Click **Isometric**  on the Standard Views toolbar. (**Ctrl-7**)

Step 10. Click **Features**  on the Command Manager toolbar.

Step 11. Click **Extruded Cut**  on the Features toolbar.

Step 12. In the Cut-Extrude Property Manager set:
 under Direction 1, **Fig. 12**
 End Condition **Through All**
 click **Reverse Direction** 
Direction arrow should point
to right, **Fig. 13**
 click OK .

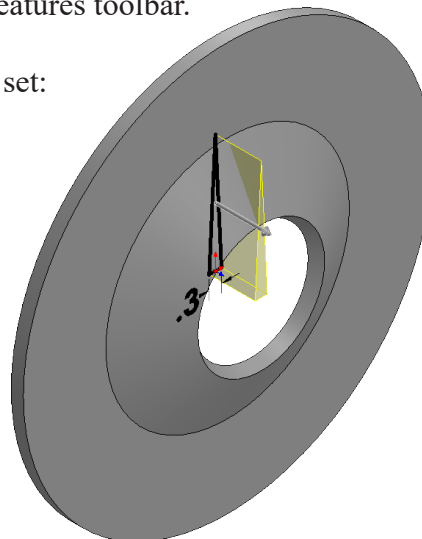

Fig. 13

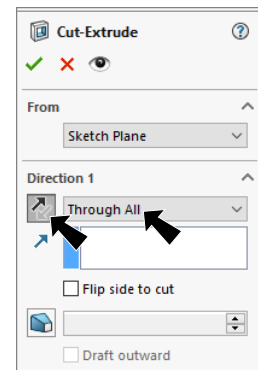
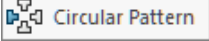





Fig. 12

D. Circular Pattern.

Step 1. Click **Circular Pattern**  in the **Linear Pattern** flyout  on the Features toolbar.

Step 2. In the Circular Pattern Property Manager set:
 under Direction 1, **Fig. 14**
 click in **Pattern Axes** box
 click **cylindrical face Retainer**
 select **Equal spacing**
Number of Instances  **6**
 under Features and Faces
 click in the Features to Pattern box
 click **Cut-Extrude1** in graphics area, **Fig. 15**
 click OK .

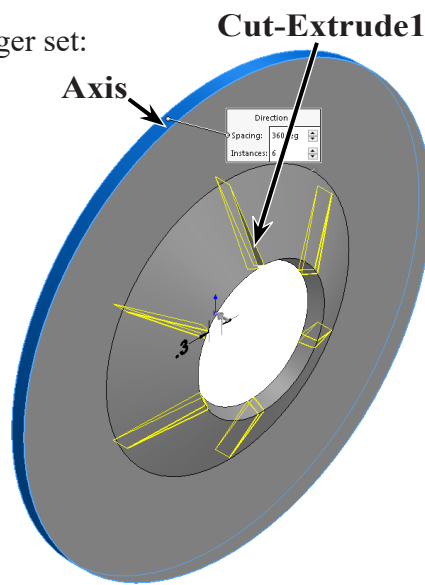

Fig. 15

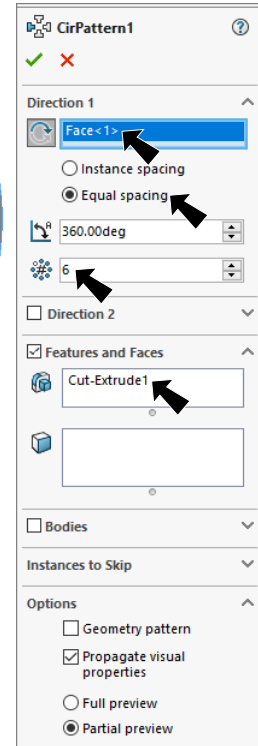



Fig. 14

E. Fillet.

Step 1. Click **Fillet**  on the Features toolbar.

Step 2. In the Fillet Property Manager:
 select **FilletXpert**, **Fig. 16**
Radius  **.13**
 click **outside cylindrical face**, **Fig. 17**
 click OK .

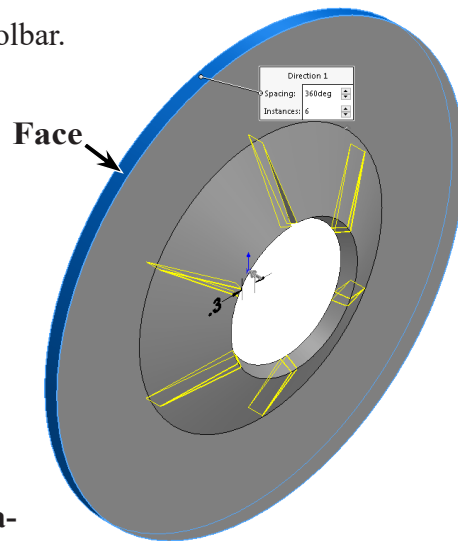

Fig. 17

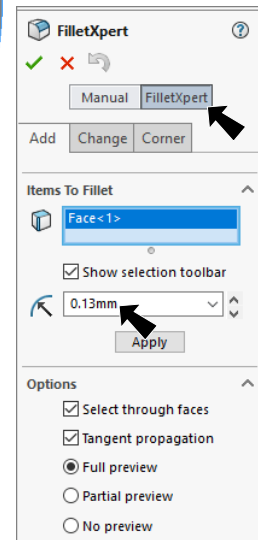

Fig. 16

F. Material Aluminum.

Step 1. **Right click** **Material**  in the Feature Manager and click **Edit Material**.

Step 2. **Expand Aluminum Alloys** in the material tree and select **1060 Alloy**. Click **Apply** and **Close**.

Step 3. Save. Use **Ctrl-S**.

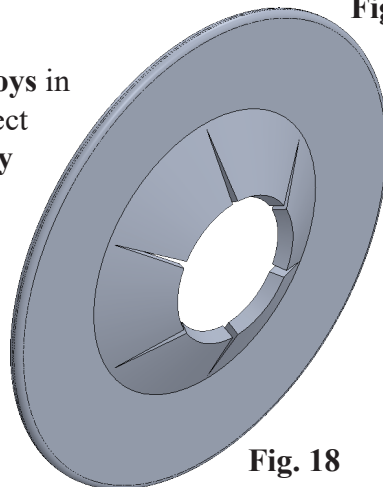

Fig. 18