



A. Sketch.

Step 1. Click File Menu > New, click **Part Metric** and OK.

Step 2. Click **Front Plane**  in the Feature Manager and click **Sketch**  on the context toolbar, **Fig. 1**.

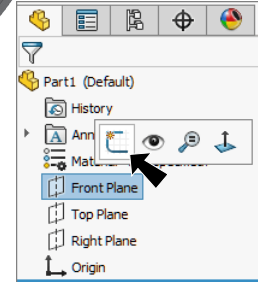



Fig. 1
Drag selection

Step 3. Click **Line**  (L) on the Sketch toolbar.

Step 4. Sketch lines, **Fig. 2**. Sketch the **vertical centerline up from the Origin**

 **last** and before moving cursor ways from line select **Construction Geometry**  on context toolbar.

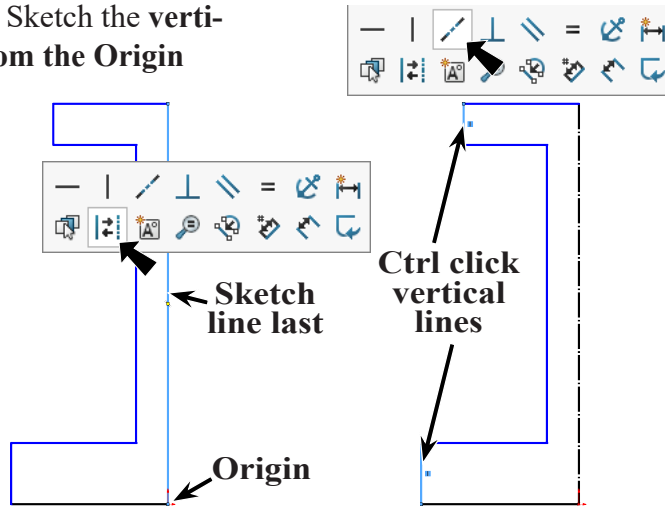

Fig. 2

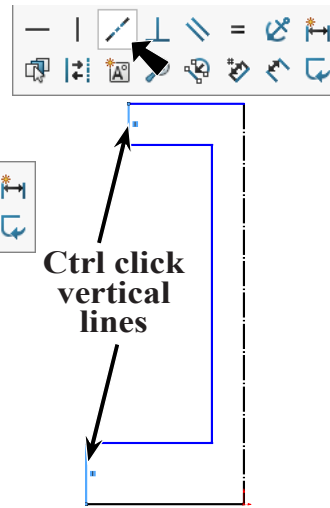



Fig. 3

Step 5. **Ctrl click both short vertical lines** to select both. Release Ctrl key and click **Make Collinear**  on the context toolbar, **Fig. 3**.

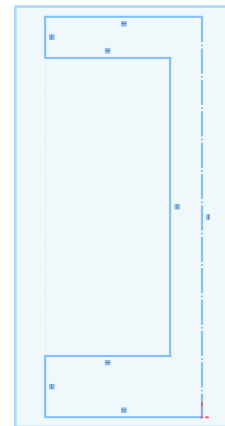



Fig. 4

Step 6. **Drag selection around the sketch** to select all lines, **Fig. 4**.

Step 7. Click **Mirror Entities**  **Mirror Entities** on the Sketch toolbar, **Fig. 5**.

Step 8. Click **Smart Dimension**  (S) on the Sketch toolbar.

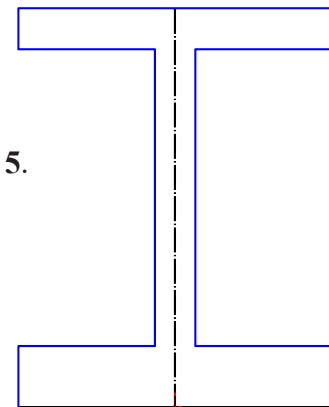

Fig. 5

Step 9. Add dimensions, **Fig. 6**.

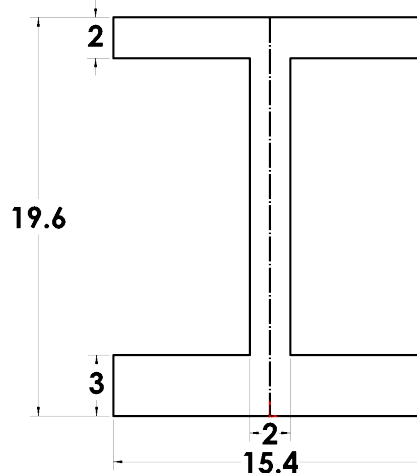

Fig. 6

B. Save as "WHEEL GT-R".

Step 1. Click File Menu > Save As.



Step 2. Key-in **WHEEL GT-R** for the filename and press ENTER.

C. Revolve.

Step 1. Click **Features**  on the Command Manager toolbar.

Step 2. Click **Revolved Boss/Base**  on the Features toolbar.

Step 3. In the Revolve Property Manger:

for Axis of Revolution ,
click **bottom line of sketch**, **Fig. 8**
click OK .

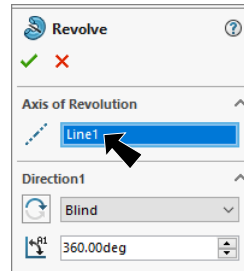

Fig. 7

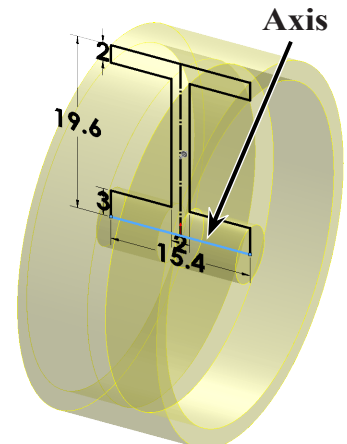





Fig. 8

D. Hole for Axle.

Step 1. Click the **side face of hub** and click **Sketch**  on the context toolbar, **Fig. 9**.

Step 2. Click **Normal To**  on the Standard Views toolbar. (**Ctrl-8**)

Step 3. Click **Circle**  (S) on the Sketch toolbar.

Step 4. Sketch a circle for the hole at Origin , **Fig. 10**.

Step 5. Click **Smart Dimension**  (S) on the Sketch toolbar.

Step 6. Dimension axle hole **diameter 3.5**, **Fig. 10**.

Step 7. Click **Features**  on the Command Manager toolbar.

Step 8. Click **Extruded Cut**  on the Features toolbar.

Step 9. In the Cut-Extrude Property Manager set:
under Direction 1, **Fig. 11**
End Condition **Through All**
click OK .

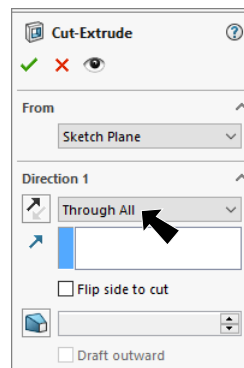

Fig. 11

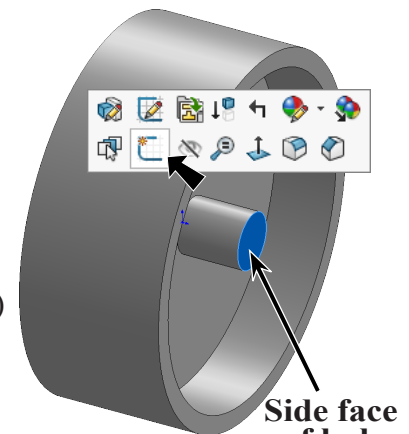

Fig. 9

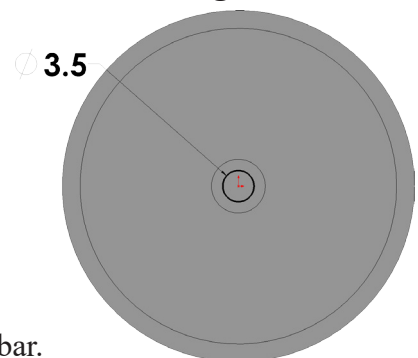

Fig. 10

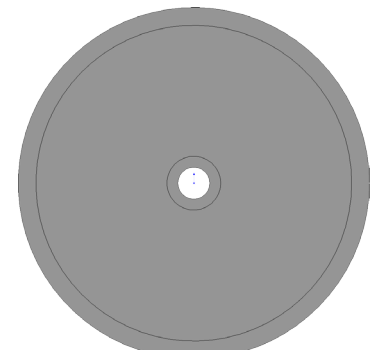



Fig. 12

E. Hole in Rim.

Step 1. Click the **side face of wheel** and click **Sketch**  on the context toolbar, **Fig. 13**.

Step 2. Click **Circle**  (S) on the Sketch toolbar.

Side face of wheel

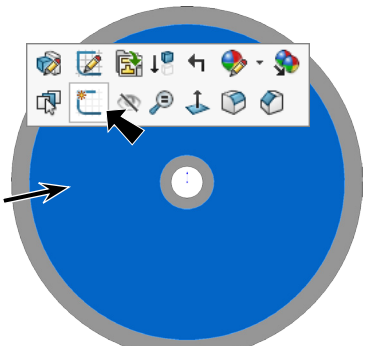





Fig. 13

Step 3. Sketch a circle for the hole above the Origin , **Fig. 14**.

Step 4. **Right click graphics area and click Select** from menu to unselect Circle tool.

Step 5. **Ctrl click centerpoint of circle and Origin**  to select both. Release Ctrl key and click **Make Vertical**  on the context toolbar, **Fig. 15**.

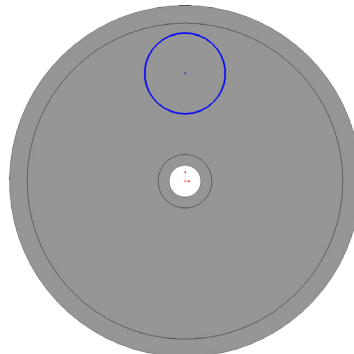

Fig. 14

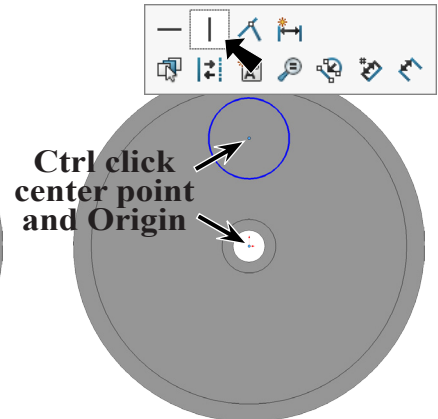



Fig. 15

Step 6. Click **Smart Dimension**  (S) on the Sketch toolbar.

Step 7. Add dimensions, **Fig. 16**.

Step 8. Click **Features**  on the Command Manager toolbar.

Step 9. Click **Extruded Cut**  on the Features toolbar.

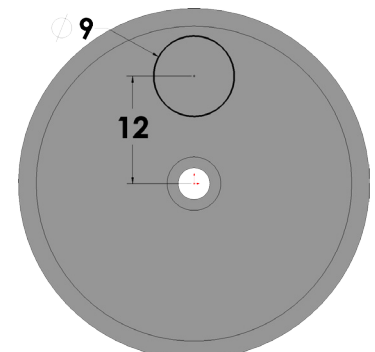



Fig. 16

Step 10. In the Cut-Extrude Property Manager set: under Direction 1, **Fig. 17**
End Condition **Through All**
click OK .

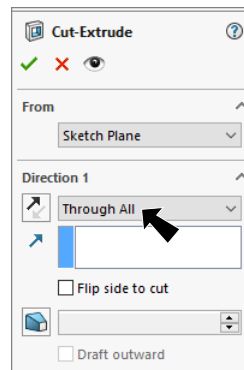

Fig. 17

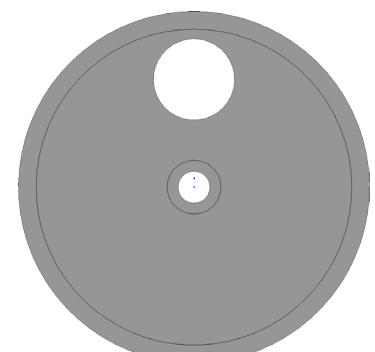





Fig. 18

F. Circular Pattern for Hole.

Step 1. Click **Isometric**  on the Standard Views toolbar. (Ctrl-7)

Step 2. Click **Circular Pattern**  in the **Linear Pattern** flyout  on the Features toolbar.

Step 3. In the Circular Pattern Property Manager set:
under Features and Faces, **Fig. 19**
click **Cut-Extrude2** in graphics area, **Fig. 20**

under Direction 1
click in **Pattern Axes** box
click **cylindrical face of hub**, **Fig. 20**

Number of Instances  **6**
check **Equal spacing**

click OK .

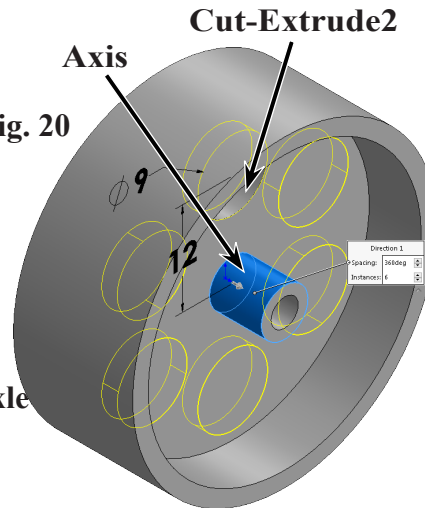

Fig. 20

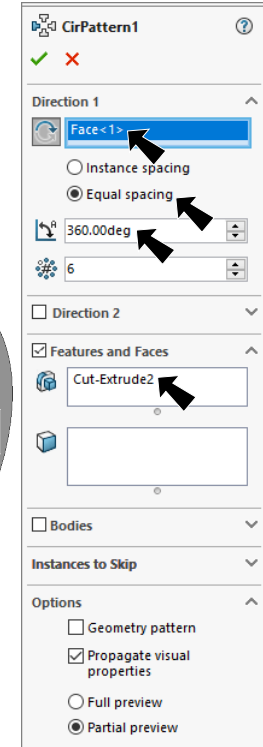
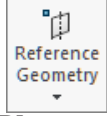

Fig. 19

G. Mate Reference.

Step 1. Click the **inside cylindrical face of axle hole** to select it, **Fig. 21**.

Step 2. Click **Reference Geometry**  on the Features toolbar and **Plane** from the menu.

Step 3. In the Mate Reference Property Manager click OK , **Fig. 22**.

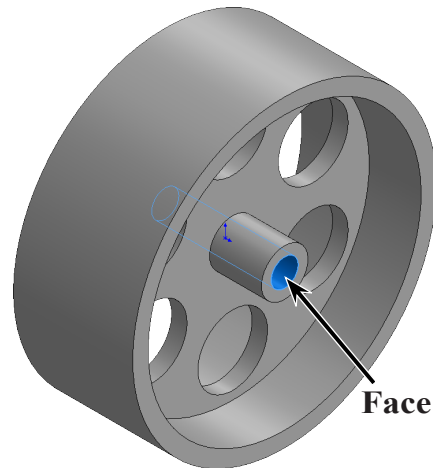

Fig. 21

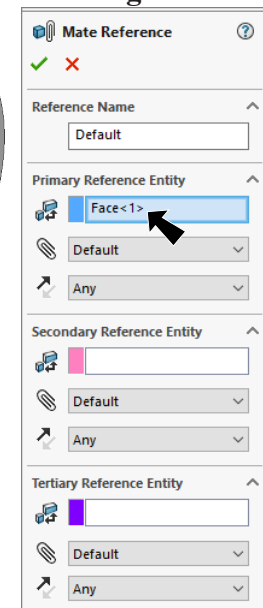

Fig. 22

H. Material POM Acetal Copolymer.

Step 1. Right click Material  in the Feature Manager and click Edit Material, Fig. 23.

Step 2. Expand **Plastics** in the material tree and select **POM Acetal Copolymer**, Fig. 24. Click Apply and Close.

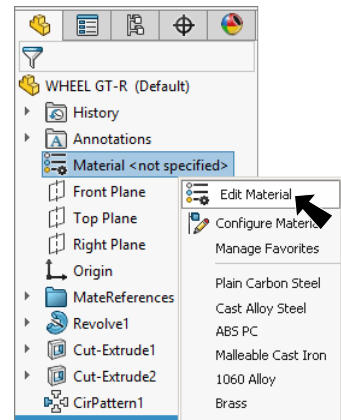

Fig. 23

I. Appearance Dark Gray.

Step 1. Click the part, click Appearance Callout  on the context toolbar and click WHEEL GT-R , Fig. 25.

Step 2. In the Appearances Task Pane expand **Plastic**, click **High Gloss** and in the lower pane click **dark grey high gloss plastic**, Fig. 26.

Step 3. Click OK  in the Property Manager.

Step 4. Save. Use **Ctrl-S**.

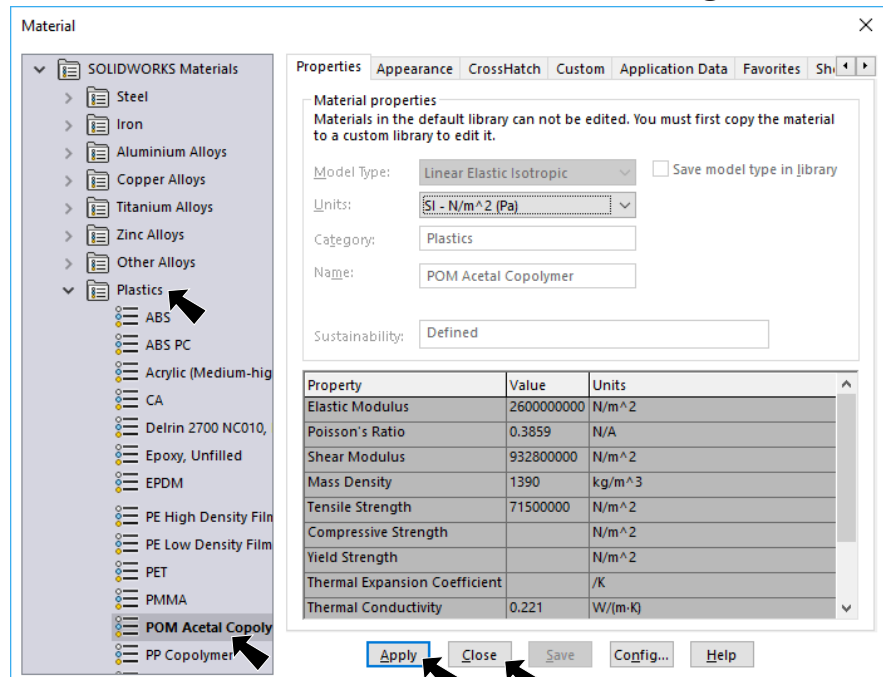

Fig. 23

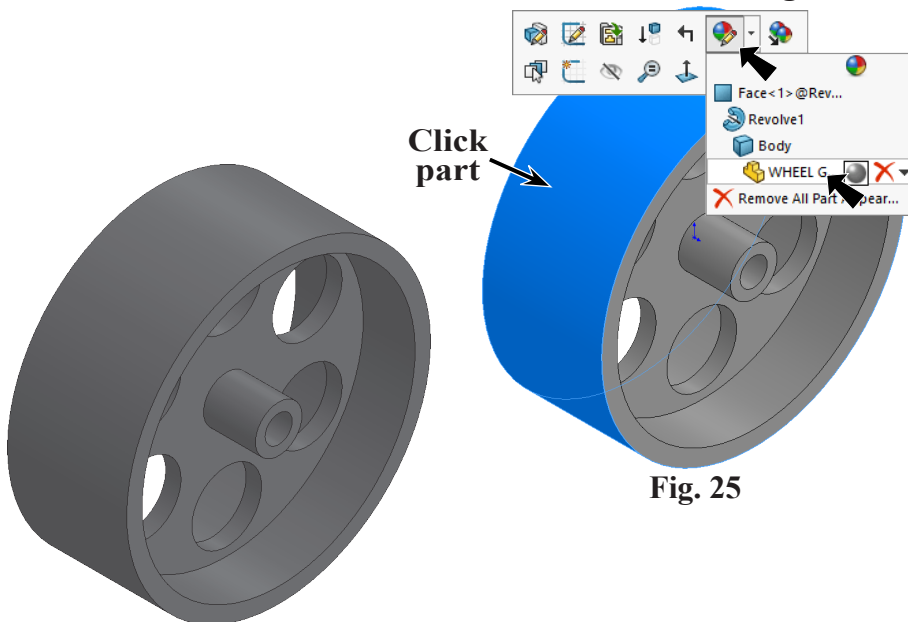

Fig. 27

Fig. 25

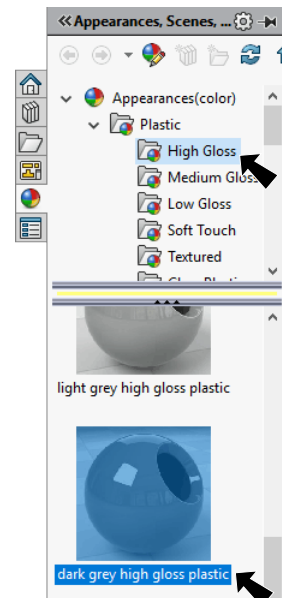

Fig. 26