



## A. Airfoil 4412 On Web.

Step 1. In your web browser, go to NACA 4412 airfoil at airfoiltools.com.  
<http://airfoiltools.com/airfoil/details?airfoil=naca4412-il>

Step 2. Click Selig format dat file, Fig. 1.

**Airfoil Tools**  
 Search 1638 airfoils

**Applications**  
 Airfoil database search  
 My airfoils  
 Airfoil plotter  
 Airfoil comparison  
 Reynolds number calc  
 NACA 4 digit generator  
 NACA 5 digit generator

**Information**  
 Airfoil data  
 Lift/drag polars  
 Generated airfoil shapes

**Searches**  
 Symmetrical airfoils  
 NACA 4 digit airfoils  
 NACA 5 digit airfoils  
 NACA 6 series airfoils

**Airfoils A to Z**  
 A a18 to avistar (88)  
 B b29root to bw3 (22)  
 C c141a to curtisc72 (40)  
 D dae11 to du861372 (28)  
 E e1098 to esa40 (209)  
 F falcon to fxs21158 (121)  
 G geminism to gu255118 (419)

**NACA 4412 (naca4412-il)**  
 NACA 4412 - NACA 4412 airfoil

**Details**  
 (naca4415-il) NACA 4415  
 NACA 4415 airfoil  
 Max thickness 15% at 30.9% chord.  
 Max camber 4% at 40.2% chord  
 Source [UIUC Airfoil Coordinates Database](#)  
[Source dat file](#)  
 The dat file is in Selig format

**Dat file**

NACA 4415	
1.00000	0.00000
0.99893	0.00039
0.99572	0.00156
0.99039	0.00349
0.98296	0.00610

**Parser**  
 No parser warnings

[Send to airfoil plotter](#)  
[Add to comparison](#)  
[Lednicer format dat file](#)  
[Selig format dat file](#)

**Similar airfoils**

Fig. 1

Step 3. In the new browser tab that opens, drag to select all but the top header line and Copy. (Ctrl-C), Fig. 2.

**Starts at (1,0013)** →

**Do not include header in selection**

**Wrong!**  
 No space in selection →

**Ends at (1,001)** →

```

NACA 4412
1.000000 0.001300
0.950000 0.014700
0.900000 0.027100
0.800000 0.048900
0.700000 0.066900
0.600000 0.081400
0.500000 0.091900
0.400000 0.098000
0.300000 0.097600
0.250000 0.094100
0.200000 0.088000
0.150000 0.078900
0.100000 0.065900
0.075000 0.050000
0.050000 0.028800
0.025000 -0.027400
0.250000 -0.025000
0.300000 -0.022600
0.400000 -0.018000
0.500000 -0.014000
0.600000 -0.010000
0.700000 -0.006500
0.800000 -0.003900
0.900000 -0.002200
0.950000 -0.001600
1.000000 -0.001300
    
```

Fig. 2

## B. New File in Excel.

Step 1. Open Excel and paste data into a new Excel file (Ctrl-V), Fig. 3.

Step 2. You can scroll to bottom and confirm 35 rows, Fig. 4.

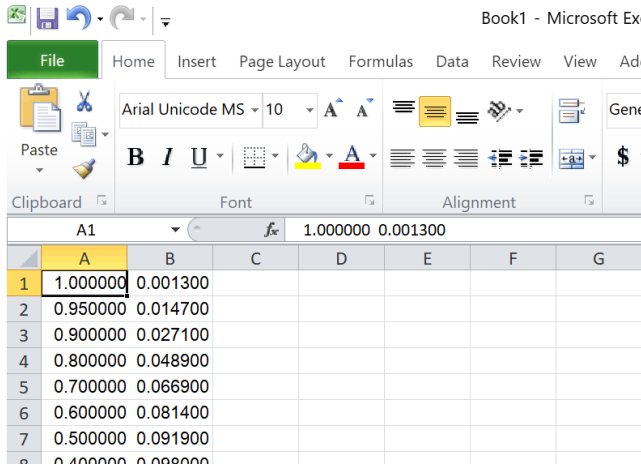


Fig. 3

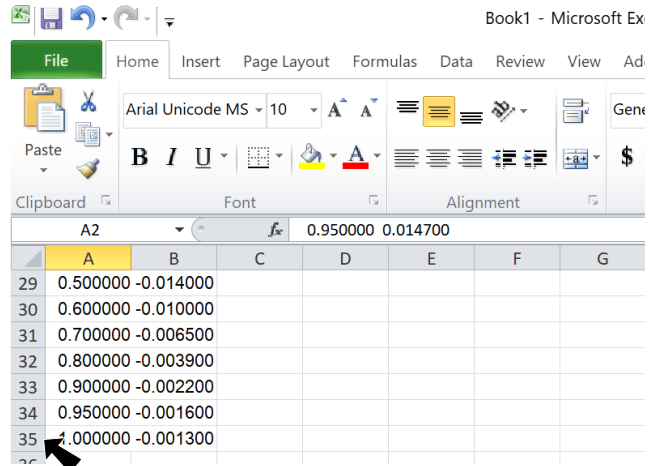


Fig. 4

Step 3. Scroll back to top and select first column, Fig. 5. To select column, click letter A heading at top of column.

Step 4. On the **Data** tab in the Data Tools group, click **Text to Columns**, Fig. 5.

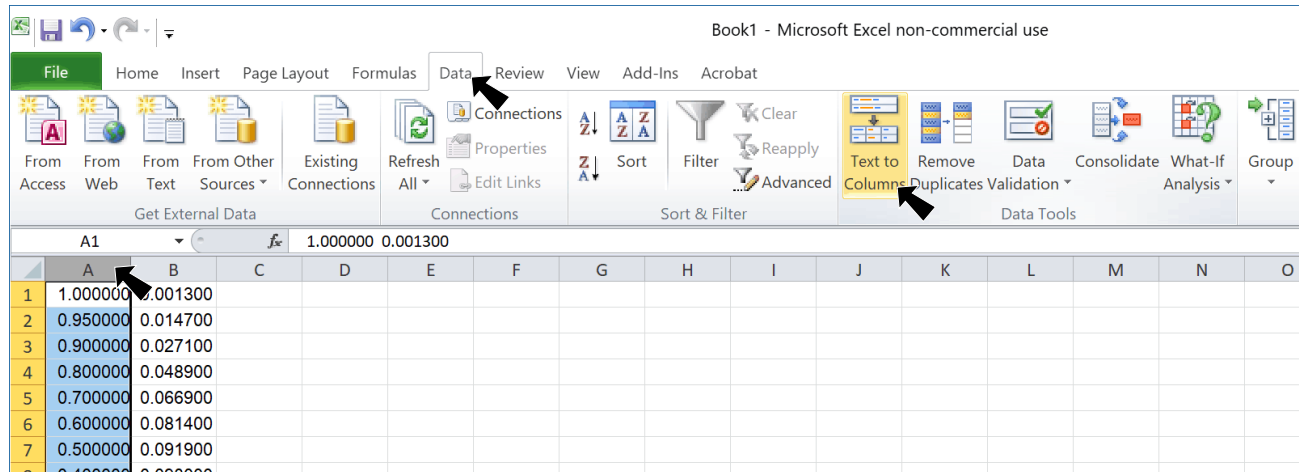


Fig. 5

Step 5. In the Convert to Columns Wizard

Step 1 Select **Delimited**

click Next

**Fig. 6**

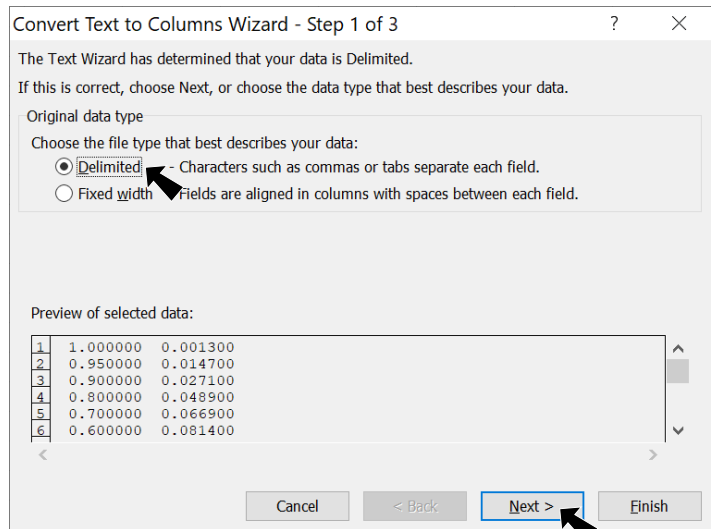
Step 2 Check **Tab and Space**

click Next

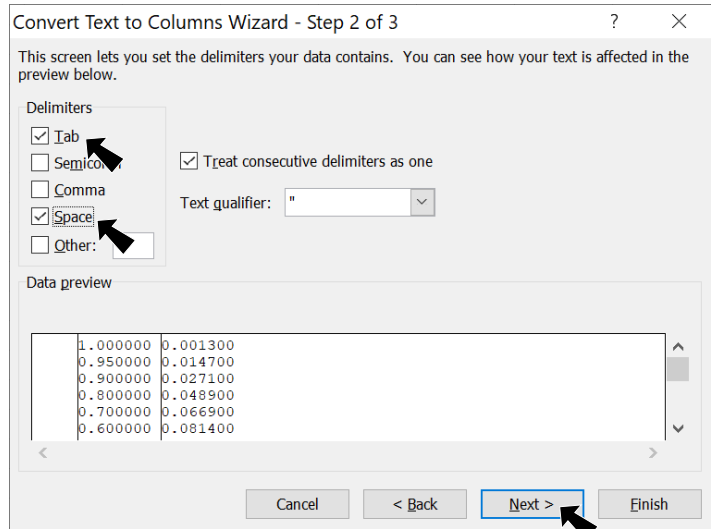
**Fig. 7**

Step 3 Click **Finish**

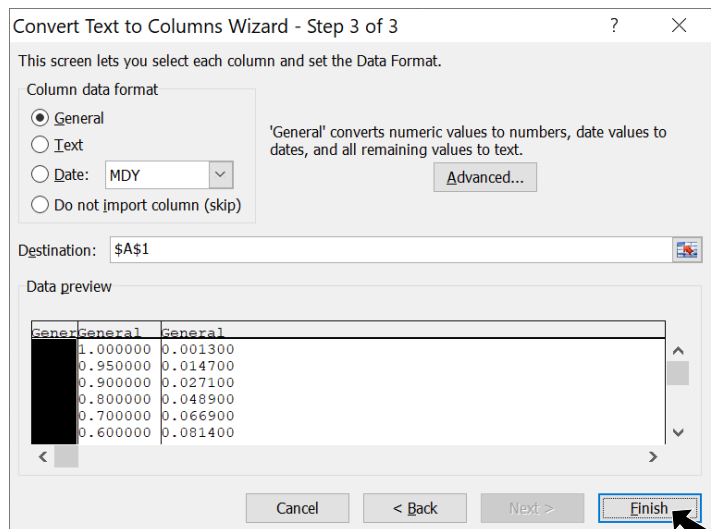
**Fig. 8.**



**Fig. 6**



**Fig. 7**



**Fig. 8**

Step 6. **Delete first blank column, Fig. 9.** To delete column, click **column A heading**, **Right click** and click **Delete**.

Step 7. Key-in a **0 (zero) in column C, Fig. 10.**

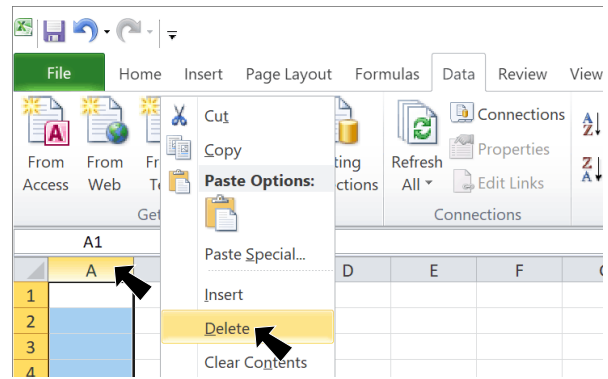
Step 8. Auto-populate all the way down. To auto-populate, **double click on bottom right corner of cell (plus sign), Fig. 11.**

Step 9. Click File Menu > Save As.

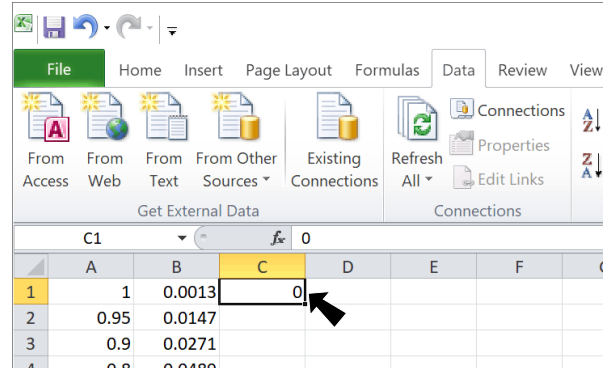
Step 10. In the Save As dialog box, **Fig. 12.**  
Key-in **AIRFOIL4412**  
**No spaces in filename**  
Navigate to **My Documents/Tech Ed 22-23/Airmaster** folder  
Set Save as type **Text (Tab delimited)**  
Click **Save**.

Click **Yes**.

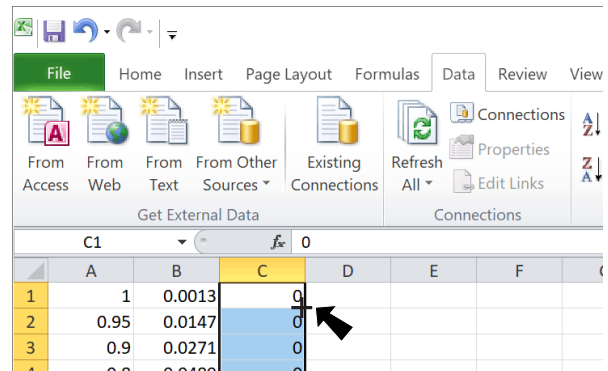
Step 11. **Close the Excel file, no need to save again.**



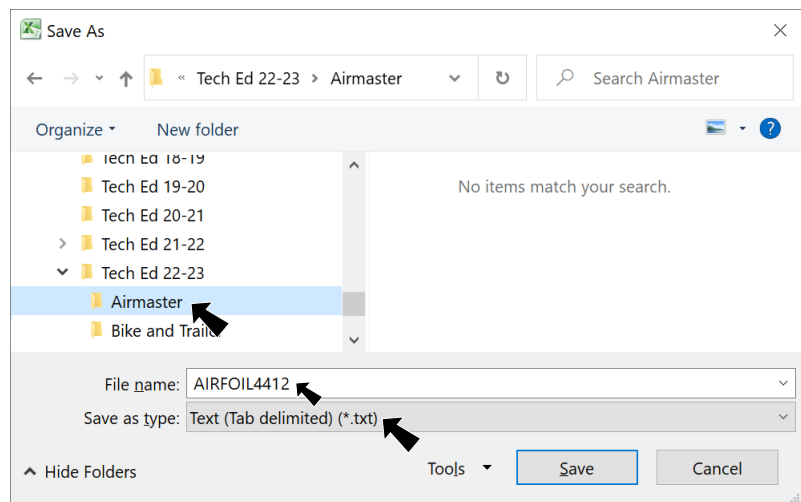
**Fig. 9**



**Fig. 10**



**Fig. 11**




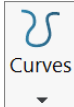
**Fig. 12**

## C. Open SOLIDWORKS Import Curve.

Step 1. Click File Menu > New, click **Part Metric** and OK.

Step 2. Click **Features**  on the Command Manager toolbar.

Step 3. Click **Curve Through XYZ Points**

 **Curve Through XYZ Points** in the **Curves flyout**  on the Features toolbar.

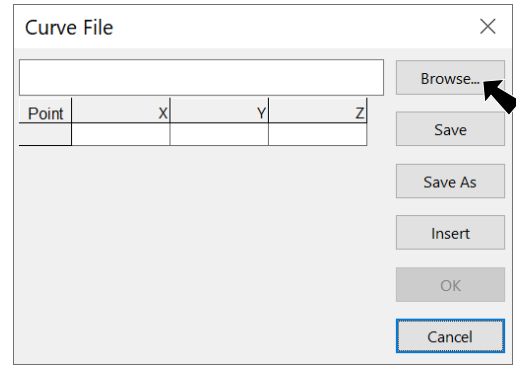


Fig. 13

Step 4. In the Curve Point dialog box: click **Browse** button, Fig. 13

Step 5. In the Open dialog box: change **file type to txt**, Fig. 14 select your txt file from Excel click **Open**

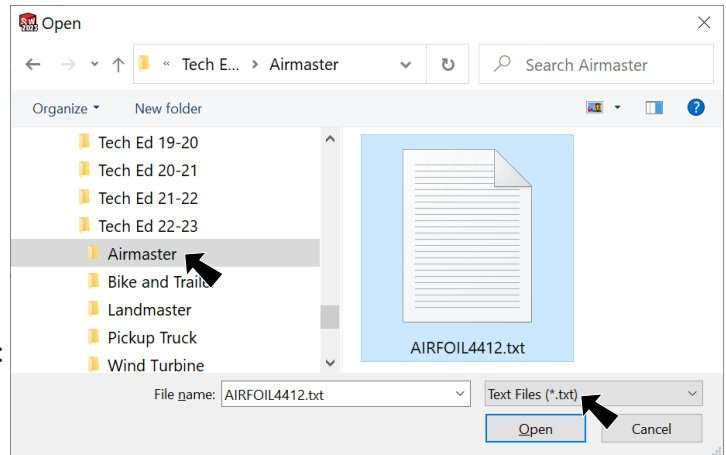



Fig. 14

Step 6. Back in the Curve Point dialog box: click **OK**, Fig. 15.

Step 7. In the graphics area the curve will be very small (1mm). Click in graphic area and **press F key to Zoom to Fit** , Fig. 16.

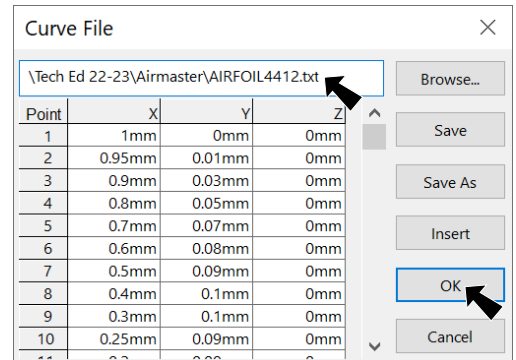


Fig. 15

## D. Save as "BLADE 4412".

Step 1. Click File Menu > Save As.

Step 2. Key-in **BLADE 4412** for the filename and press ENTER.

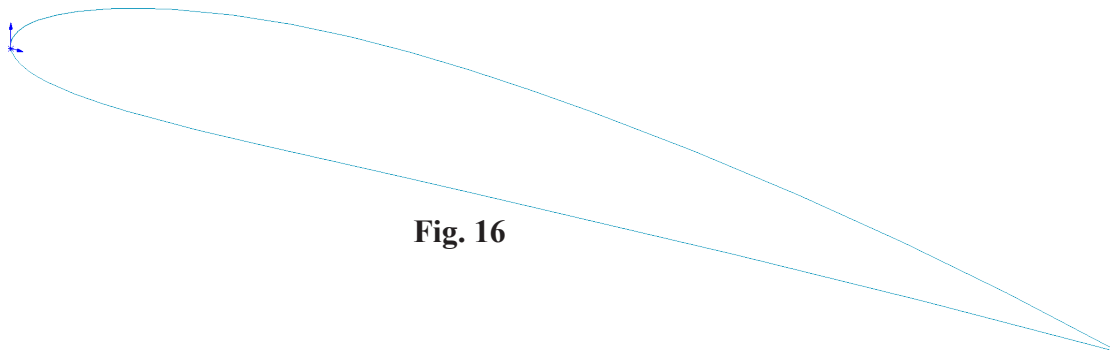


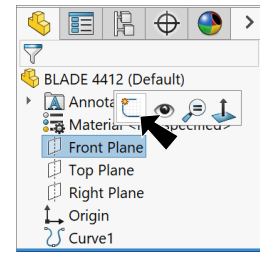


Fig. 16


## E. Sketch1 for Boundary Surface.

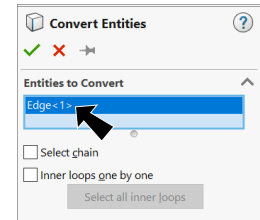
Step 1. Click **Front Plane**  in the Feature Manager and click **Sketch**  on the context toolbar, **Fig. 17**.



**Fig. 17**

Step 2. Click **Convert Entities**  on the Sketch toolbar.

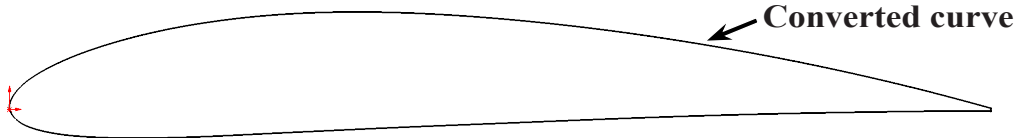
Step 3. In the Convert Entities Property Manager:  
 under Entities to Convert, **Fig. 18**  
 click **Curve**, **Fig. 19**  
 click OK .



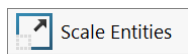
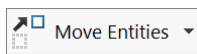
**Fig. 18**




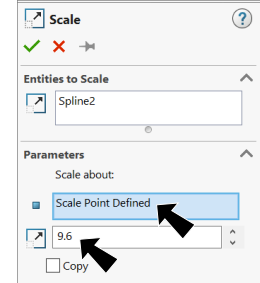
**Fig. 19**




**Fig. 20**

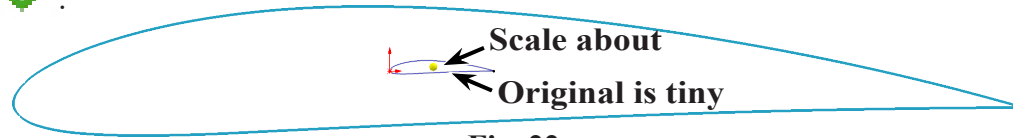
Step 4. Click **Scale Entities**  in the **Move Entities** flyout  on the Sketch toolbar.

Step 5. In the Scale Property Manager set:  
 under Entities to Scale, **Fig. 21**  
 click **converted curve spline**, **Fig. 22**  
 under Parameters  
 click in Scale about box  
 click **in middle of spline**  
**Scale Factor**  **9.6**  
 uncheck **Copy**



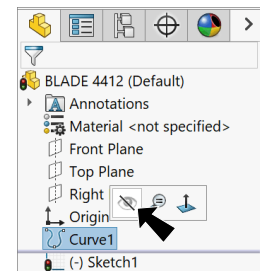
**Fig. 21**

**Tip:** Click in the graphics area and use F key to Zoom to Fit  
 click OK .





**Fig. 22**

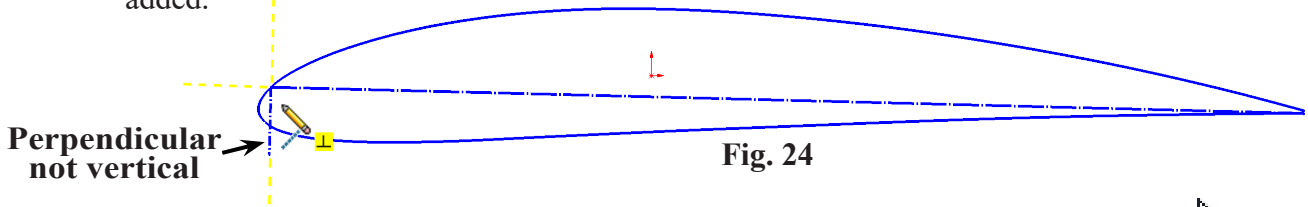
Step 6. **Hide Curve1** . To hide, click **Curve1**  in the Feature Manager and **Hide**  on the context toolbar, **Fig. 23**.





**Fig. 23**

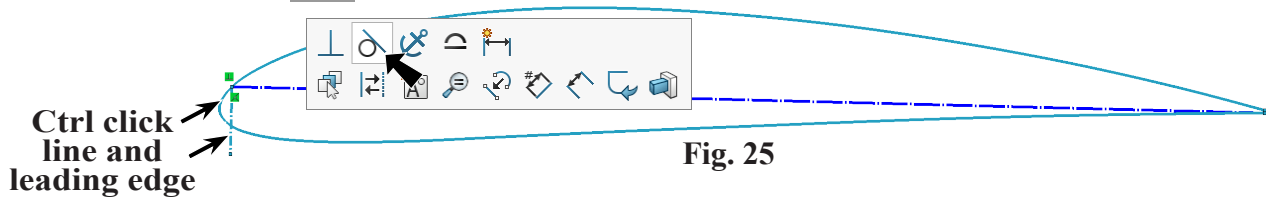
Step 7. Click **Centerline**  in the **Line flyout**  on the Sketch toolbar.



Step 8. Sketch **cord construction line from trailing edge bottom endpoint of spline to leading edge and a perpendicular construction line down from endpoint of cord**, Fig. 24.  
As you sketch, position cursor until it changes to   to show perpendicular relations is added.

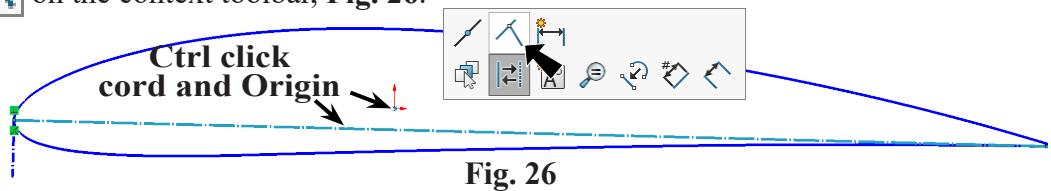


Step 9. **Unselect Centerline tool.** To unselect, **right click graphics area and click Select**  from menu.

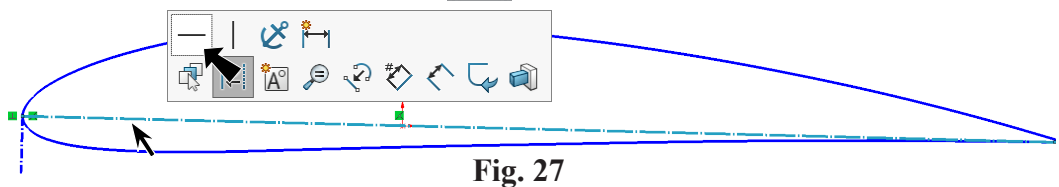
Step 10. **Ctrl click the spline and perpendicular line to select both.** Release Ctrl key and click **Make Tangent**  on the context toolbar, Fig. 25.



Step 11. **Ctrl click cord line and Origin**  to select both. Release Ctrl key and click **Make Coincident**  on the context toolbar, Fig. 26.

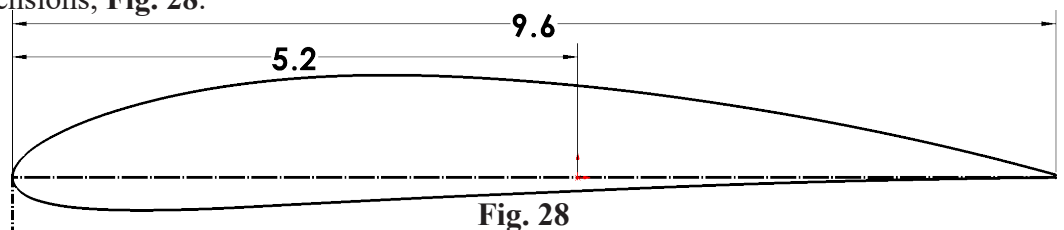


Step 12. Click **cord line** and click **Make Horizontal**  on the context toolbar, Fig. 27.

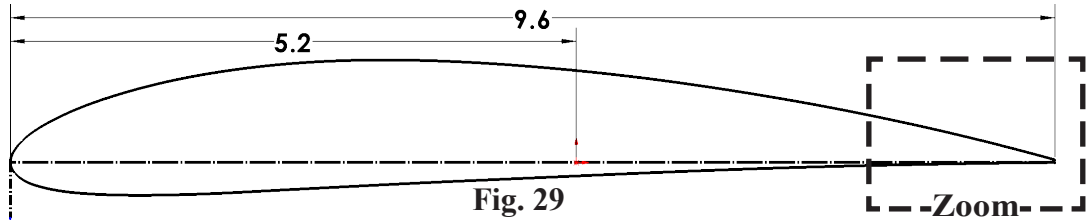


Step 13. Click **Smart Dimension**  (S) on the Sketch toolbar.

Step 14. Add dimensions, Fig. 28.



Step 15. Zoom in around the **trailing edge**, Fig. 29.



Step 16. Click **Centerline**  in the **Line flyout**  on the Sketch toolbar.

Step 17. Sketch **construction line at angle** across **trailing edge**, Fig. 30.

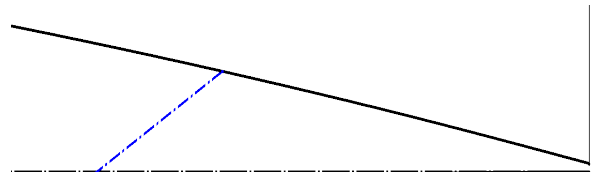


Fig. 30

Step 18. Click **Smart Dimension**  (S) on the Sketch toolbar.

Step 19. Add dimensions, Fig. 31.

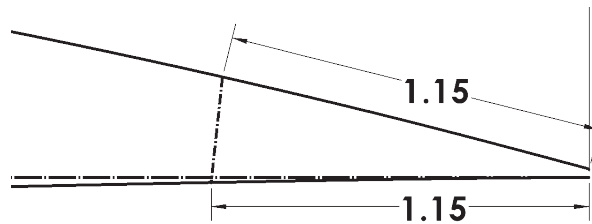


Fig. 31


Step 20. Click **Trim Entities**  (S) on the Sketch toolbar.

Step 21. In the Trim Property Manger:

select **Trim to closest** , Fig. 32  
check **Keep trimmed entities as construction geometry**

Trim rear segments of bottom ends of spline to construction line, Fig. 33.

Click segment to trim. Results shown in Fig. 34.

Click OK  when done.

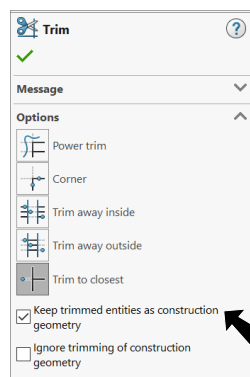


Fig. 32

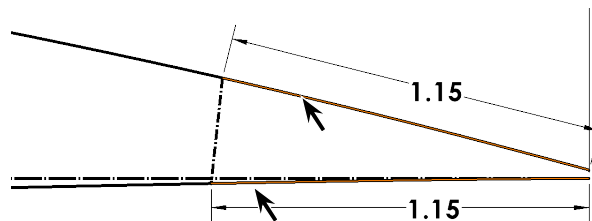


Fig. 33

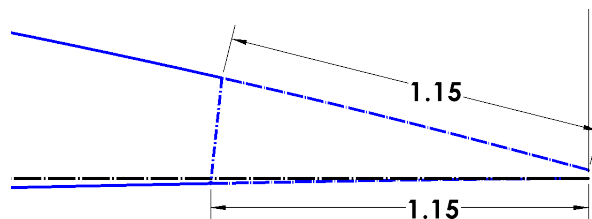



Fig. 34

Step 22. Click **top spline most rear endpoint** (trimmed construction spline) and click **Make Fixed**  on the context toolbar, **Fig. 35**. This will fully define sketch.

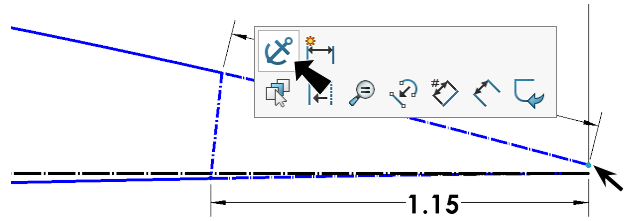


Fig. 35

Step 23. Click **Style Spline**  in the **Spline fly-out**  on the Sketch toolbar.

Step 24. Sketch a **4 control vertex point Spline** between endpoints of trailing edge spline, **Fig. 36**. Press Escape to end spline.

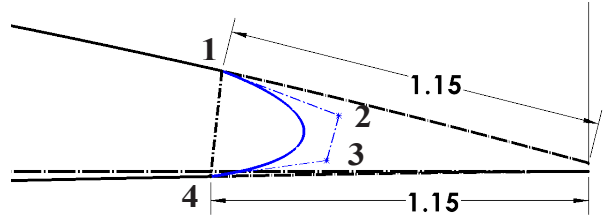



Fig. 36

Step 25. **Ctrl click top construction geometry of trim and top control vertex point** to select both. Release Ctrl key and click **Make Coincident**  on the context toolbar, **Fig. 37**.

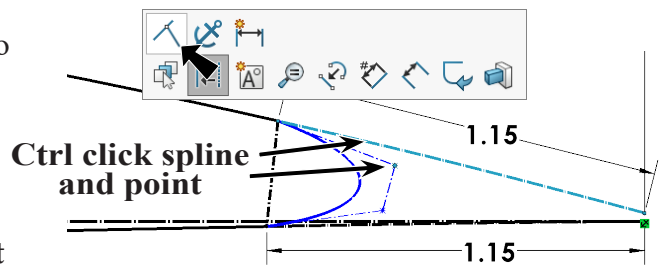



Fig. 37

Step 26. **Ctrl click bottom control vertex point and bottom construction geometry of trim** to select both. Release Ctrl key and click **Make Coincident**  on the context toolbar, **Fig. 38**.

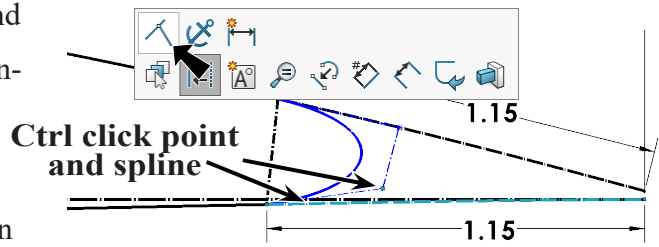



Fig. 38

Step 27. Click **Smart Dimension**  (S) on the Sketch toolbar.

Step 28. Add dimensions, **Fig. 39**.

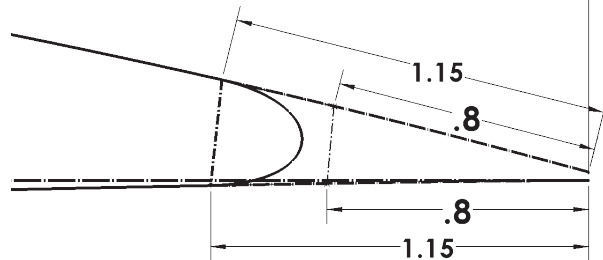


Fig. 39

Step 29. Save  (Ctrl-S).

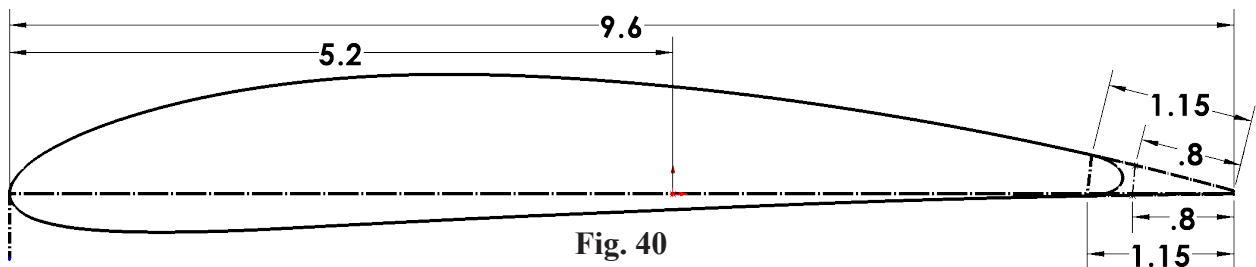
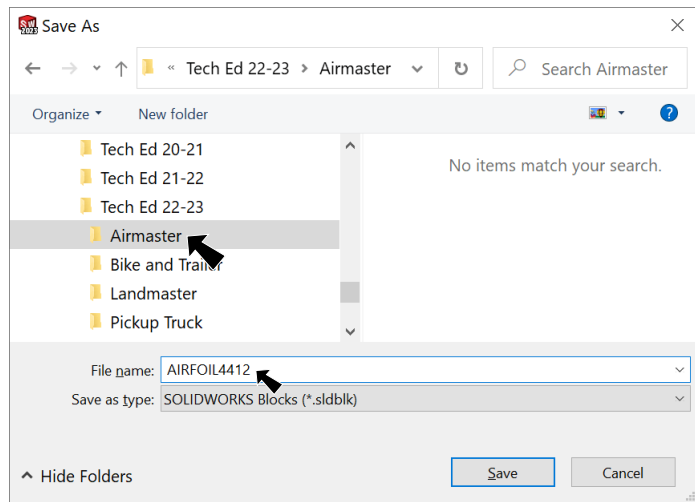


Fig. 40

## F. Save Sketch as Block.

Step 1. Click Tools Menu > Blocks > Save.

Step 2. In the Save As dialog box, **Fig. 41** key-in **AIRFOIL4412** for the filename navigate to **Documents\Tech Ed 22-23\Airmaster** click Save button.




**Fig. 41**

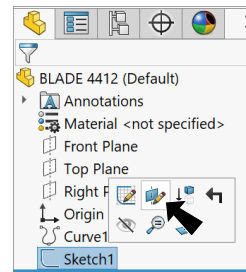
Step 3. Click **Exit Sketch**  on the Sketch toolbar.

Step 4. Save  (Ctrl-S).

## G. Change Sketch Plane.

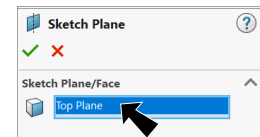
Step 1. Click **Isometric**  on the Standard Views toolbar. (Ctrl-7)

Step 2. Click **Sketch1**  in the Feature Manager and click **Edit Sketch Plane**  on the context toolbar, **Fig. 42**.

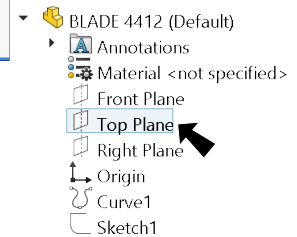


**Fig. 42**

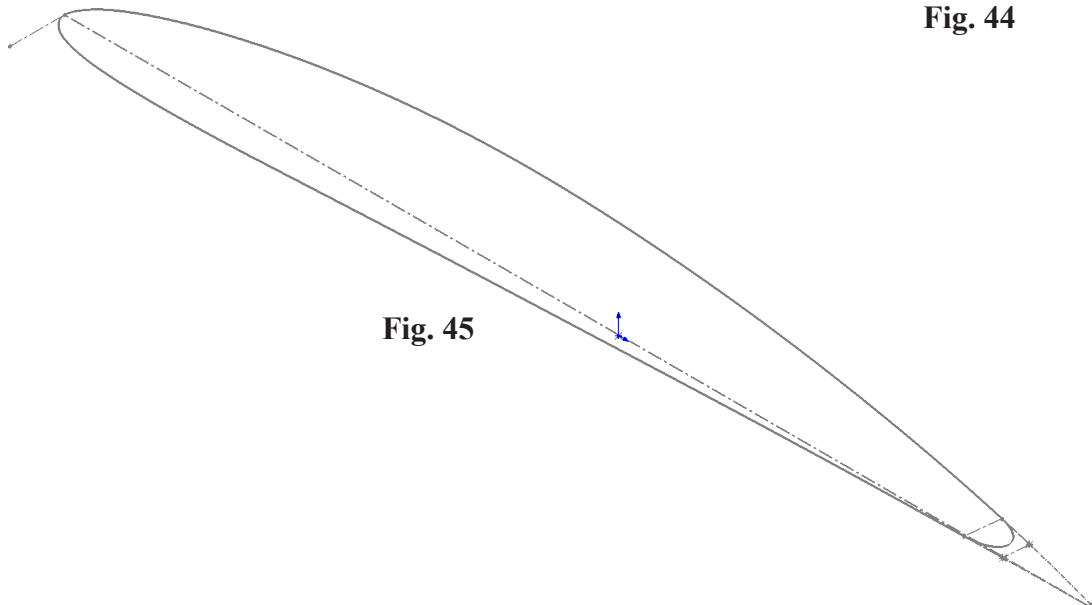
Step 3. In the Sketch Plane Property Manager: under Sketch Plane/Face, **Fig. 43** expand the flyout Feature Manager design tree in top left corner of the graphics area and click **Top Plane** , **Fig. 44** click OK .



**Fig. 43**




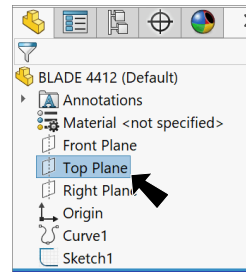
**Fig. 44**



**Fig. 45**

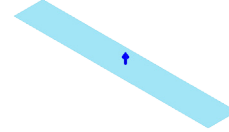
## H. Create Plane1 and Plane2.

Step 1. Click **Top Plane**  in the Feature Manager to display Plane in graphics area, **Fig. 46**.

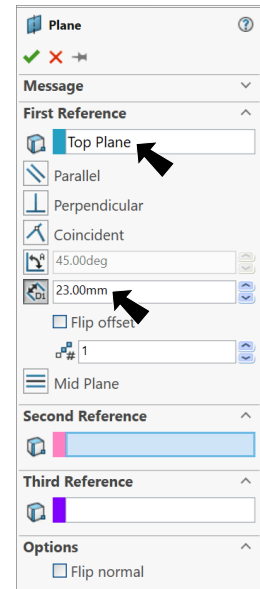


**Fig. 46**

Step 2. In graphics area **Ctrl drag Top plane to up** and release, **Fig. 47**.




Step 3. In the Plane Property Manager set:  
under First Reference, **Fig. 48**







**Fig. 48**

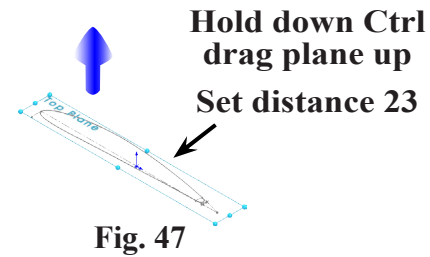
**Distance**  **23**  
and press **ENTER**.

The new plane should be above, **Fig. 47**.

**Tip:** Click in the graphics area and use F key to  
Zoom to Fit 

Click **Keep Visible**  and **OK** . The Push Pin  on allows creating another Plane.



Step 4. In the Plane Property Manager:  
under First Reference, **Fig. 49**  
click in First Reference box  
expand the flyout Feature Manager design  
tree in top left corner of the graphics area  
and click **Top Plane** , **Fig. 50**

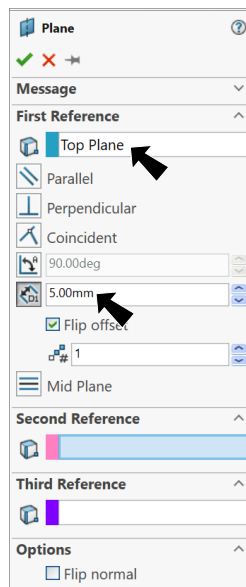


**Fig. 47**

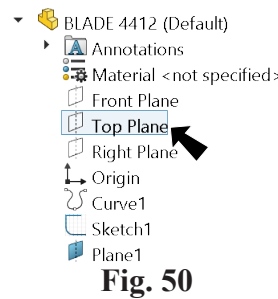
**Distance**  **5**

check **Flip offset**  
The new plane should be **below Top Plane**,  
**Fig. 51**.

Click **OK**  and click  
**Cancel** .

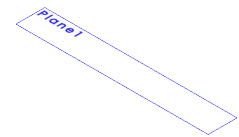


**Fig. 49**

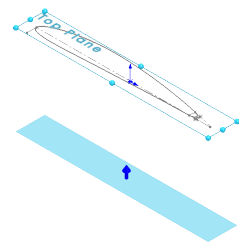


**Fig. 50**

Step 5. Save  (**Ctrl-S**).



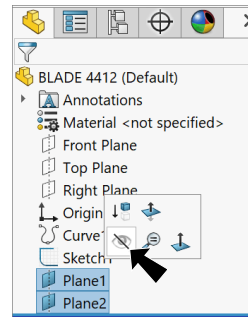
**Set distance 5 flip**



**Fig. 51**

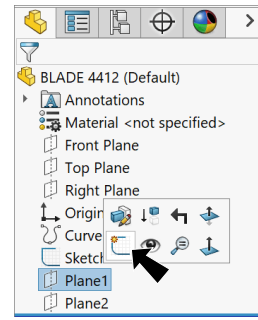
## I. Insert AIRFOIL 4412 Block.

Step 1. **Hide Plane1** and **Plane2**. To hide, **Ctrl** click **Plane1** and **Plane2** in the Feature Manager and **Hide** on the context toolbar, **Fig. 52**.



**Fig. 52**

Step 2. Click **Plane1** in the Feature Manager and click **Sketch** on the context toolbar, **Fig. 53**.

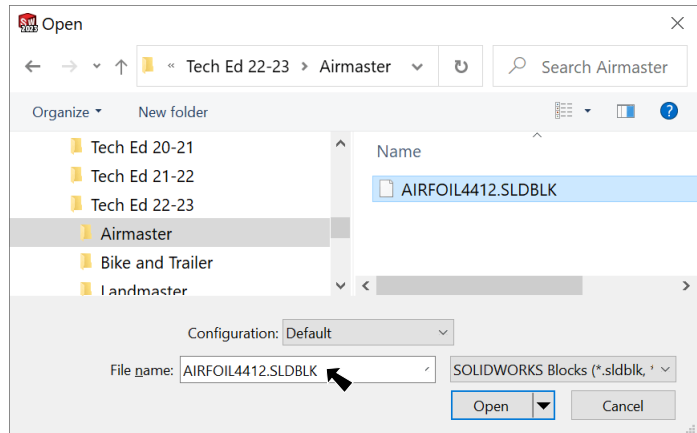


**Fig. 53**

Step 3. Click **Normal To** on the Standard Views toolbar. (**Ctrl-8**)

Step 4. Click Tools Menu > Blocks > Insert.

Step 5. In the Open dialog box select your Block file and Open, **Fig. 54**.



**Fig. 54**

Step 6. In Insert Block Property Manager, click **Browse**, **Fig. 55** in the Open dialog box, navigate to **Documents\Tech Ed 22-23\Air-master** and open **AIRFOIL4412** block file

under Parameters

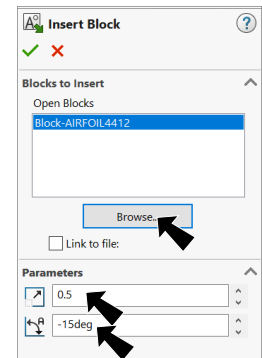
**Block Scale**  **.5**

**Block Rotation**  **-15°**

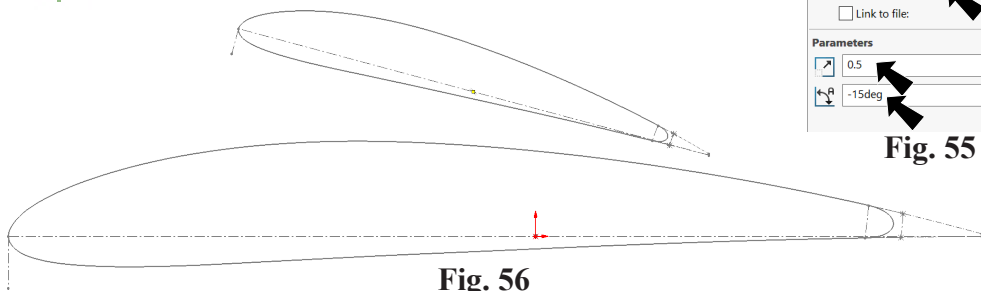
press **ENTER** key on keyboard

click above the geometry in **Sketch1**, **Fig. 56**

click **OK** .


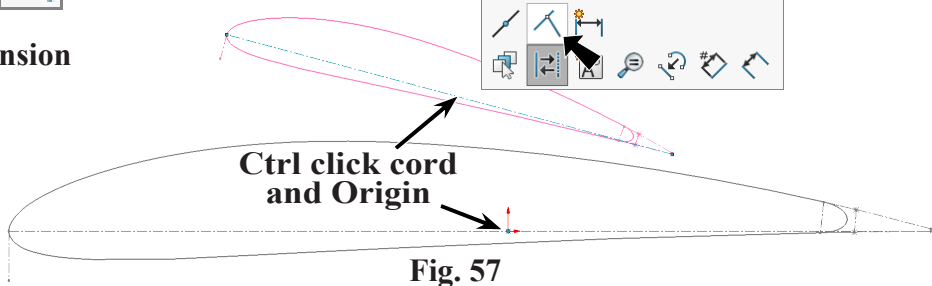


**Fig. 55**


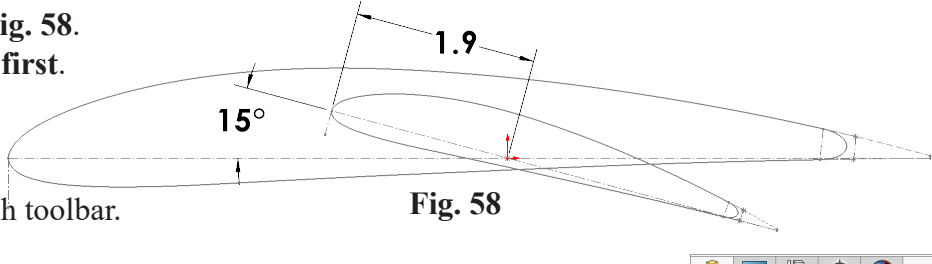


**Fig. 56**

Step 7. **Ctrl click cord line in the block and Origin**  to select both. Release Ctrl key and click **Make Coincident**  on the context toolbar, **Fig. 57**.

Step 8. Click **Smart Dimension**  (S) on the Sketch toolbar. 

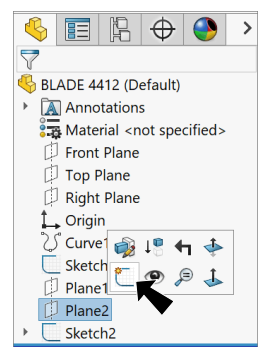
Step 9. Add dimensions, **Fig. 58**. Dimension the **15°** first.

Step 10. Click **Exit Sketch**  on the Sketch toolbar. 


**J. Sketch3.**

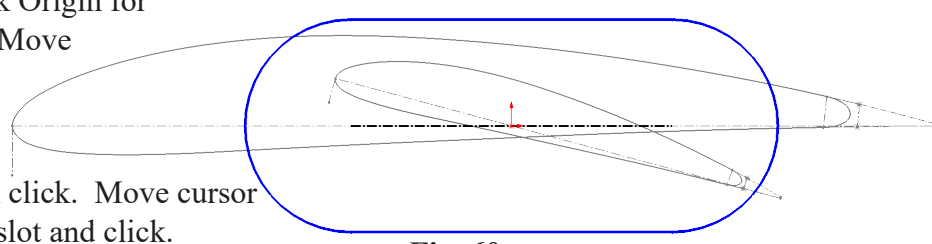
Step 1. Click **Plane2**  in the Feature Manager and click **Sketch**  on the context toolbar, **Fig. 59**.

Step 2. Click **Center Straight Slot**  (S) in the **Straight Slot** flyout  on the Sketch toolbar.



**Fig. 59**


Step 3. Sketch a Center Straight slot at the **Origin** , **Fig. 60**. To sketch slot, click Origin for start point of slot. Move cursor to right to cord line in Sketch1 for length of the slot and then click. Move cursor down for width of slot and click.

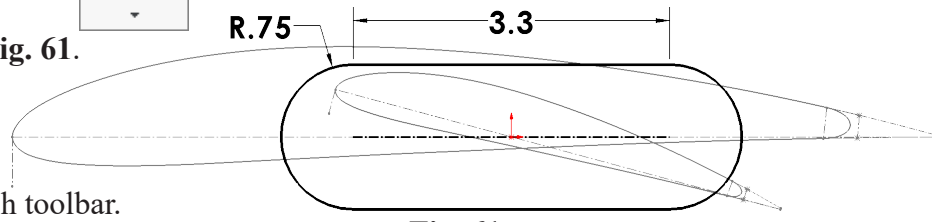


**Fig. 60**

Step 4. Click **Smart Dimension**  (S) on the Sketch toolbar.

Step 5. Add dimensions, **Fig. 61**.

Step 6. Click **Exit Sketch**  on the Sketch toolbar.



**Fig. 61**




## K. Surface Filled1.

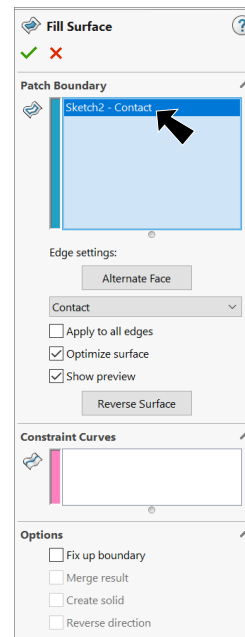
Step 1. Click **Isometric**  on the Standard Views toolbar. (Ctrl-7)

Step 2. Click **Surfaces**  on the Command Manager toolbar.

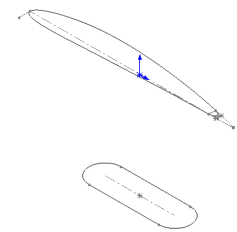
Step 3. Click **Filled Surface**  on the Surfaces toolbar.

Step 4. In the Fill Surface Property Manger set:  
 under Patch Boundary, **Fig. 62**  
 click **Sketch2**, **Fig. 63**  
 check **Optimize surface**  
 check **Show preview**

**Tip:** Right click when cursor changes to  to select OK .  
 or click OK .




**Fig. 62**



**Fig. 63**

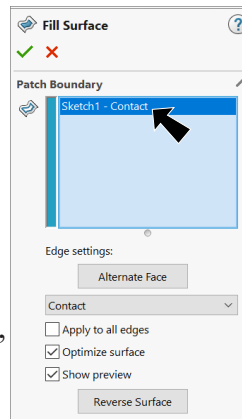
## L. Surface Filled2 and 3.

Step 1. Click **Filled Surface**  on the Surfaces toolbar.

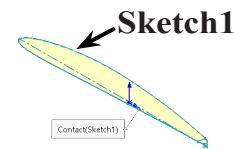
Step 2. In the Fill Surface Property Manger:  
 under Patch Boundary, **Fig. 64**  
 click **Sketch1**, **Fig. 65**  
 check **Optimize surface**  
 check **Show preview**  
 click OK .

Step 3. Repeat and add Fill Surface **Sketch3**, **Fig. 66**

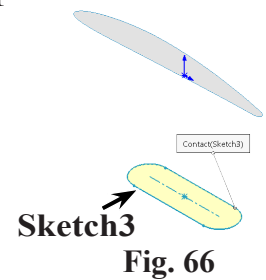
Step 4. Save  (Ctrl-S).



**Fig. 64**




**Fig. 65**



**Fig. 66**

## M. Boundary Surface 1.

Step 1. Click **Boundary Surface**  on the Surfaces toolbar.

Step 2. In the Boundary-Surface Property Manger:  
 under Direction 1, **Fig. 67**  
 click **Surface-Fill1**, **Fig. 68**  
 click **Surface-Fill2**  
 click OK .

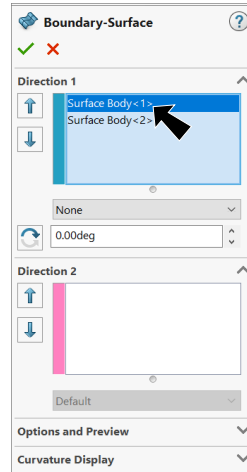
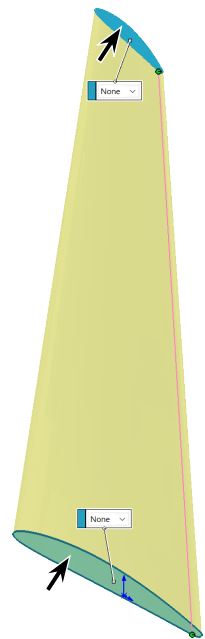



Fig. 67



## N. Boundary Surface 2.

Step 1. Rotate view up to view of Surface Fill2, use **Up Arrow** key  four times.

Step 2. Click **Boundary Surface**  on the Surfaces toolbar.

Step 3. In the Boundary-Surface Property Manger:  
 under Direction 1, **Fig. 69**  
 click **Surface-Fill2**, **Fig. 70**  
 click **Surface-Fill3**

Tangent Type

set **Normal To Profile** for **Surface body 1 only**

Alignment

**Align With Next Section**

drag connectors  to aligned as shown **Fig. 70**

Click **Front**  on the Standard Views toolbar.

Again adjust connectors  as shown **Fig. 71**

click OK .

Step 4. Save  (**Ctrl-S**).

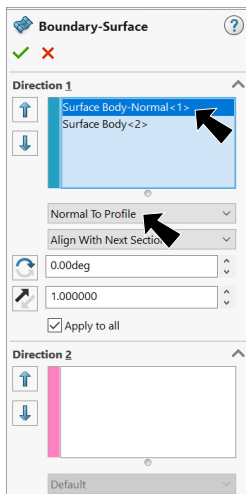


Fig. 69

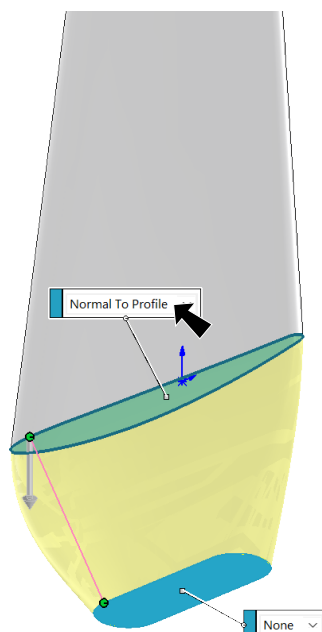


Fig. 70



Fig. 71

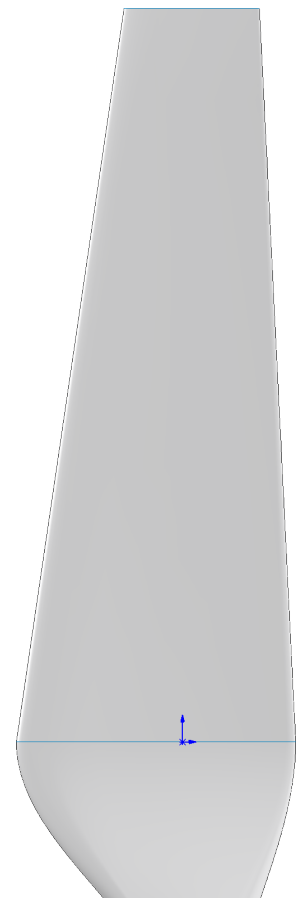


Fig. 72

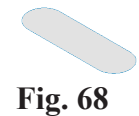






Fig. 68

## O. Knit Surfaces 1.

Step 1. Click **Isometric**  on the Standard Views toolbar. (Ctrl-7)

Step 2. **Hide Surface-Fill2** , the middle Surface Fill.  
To hide, expand Surfaces Bodies  folder in the Feature Manager, click **Surface-Fill2**  and **Hide**  on the context toolbar, Fig. 73.

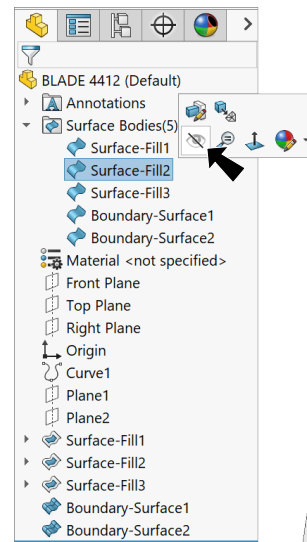



Fig. 73

Step 3. Click **Knit Surface**  on the Surfaces toolbar.

Step 4. In the Knit Surface Property Manger:  
under Selections, Fig. 75  
click **both boundary surfaces**, Fig. 76  
check **Merge entities**  
check **Gap Control**  
click OK .

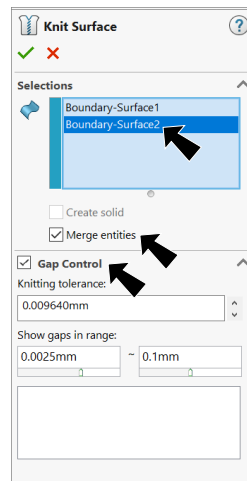


Fig. 75

**Hide Surface-Fill2**

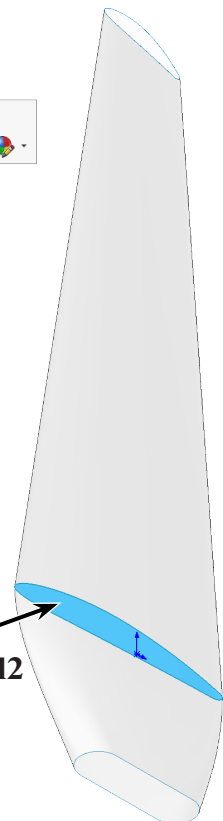


Fig. 74

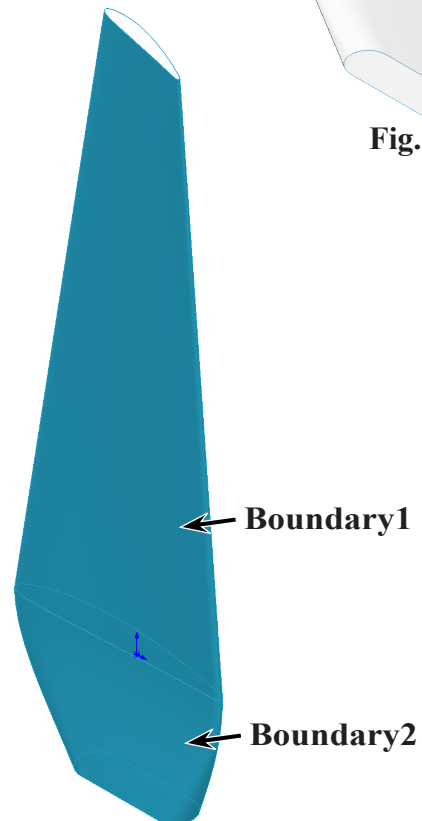


Fig. 76

## P. Knit Surfaces2.


Step 1. Click **Knit Surface**  on the Surfaces toolbar.

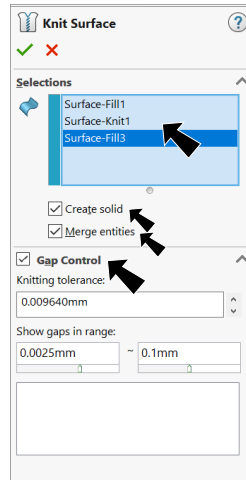
Step 2. In the Knit Surface Property Manger:  
under Selections, **Fig. 77**  
click:

**top fill surface**  
**knit surface, Fig. 78**

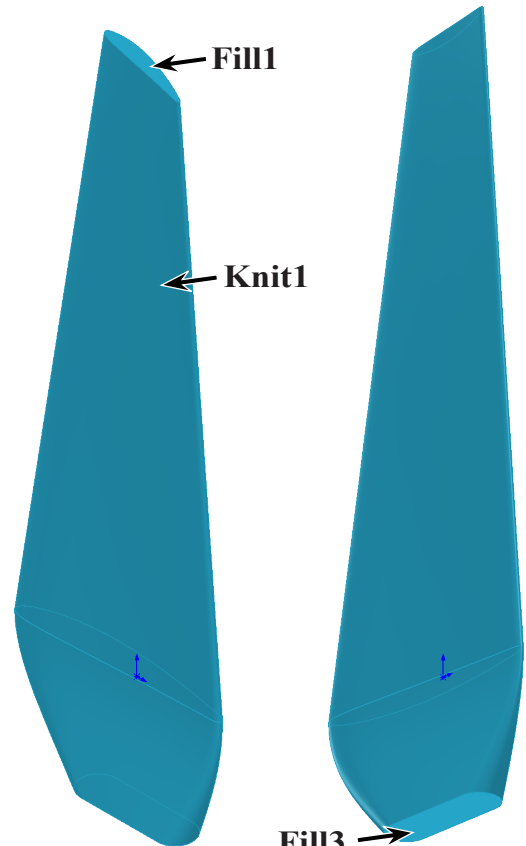
Rotate to view bottom  
click:

**bottom fill surface,**  
**Fig. 79**

check **Create solid**  
check **Merge entities**  
check **Gap Control**  
click OK .



**Fig. 77**



**Fig. 78**



**Fill3** **Fig. 79**


Step 3. Save  (Ctrl-S).

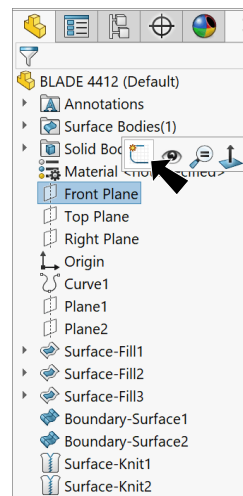
## Q. Extrude Cut Tip.

Step 1. Click **Front Plane**  in the Feature Manager and click **Sketch**  on the context toolbar, **Fig. 80**.

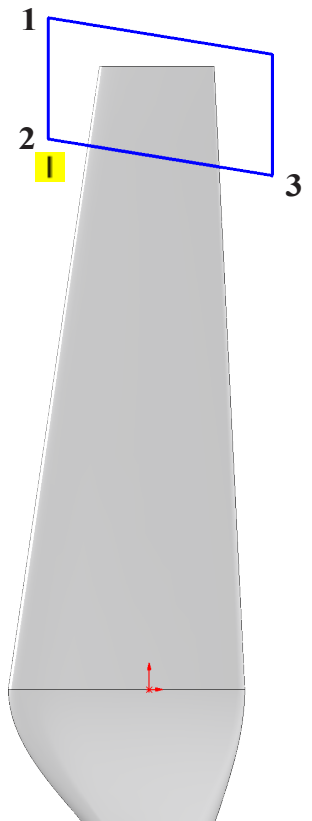
Step 2. Click **Normal To**  on the Standard Views toolbar. (Ctrl-8)

Step 3. Click **Parallelogram**  in the **Rectangle fly-out**  on the Sketch toolbar.

Step 4. Sketch parallelogram with vertical sides at tip of blade, **Fig. 81**. To sketch parallelogram, click first corner upper left of tip of blade. For second corner, move cursor down directly below first corner until it changes to show vertical relations  is added and click. Sketch third corner to right and slight below to set angle.



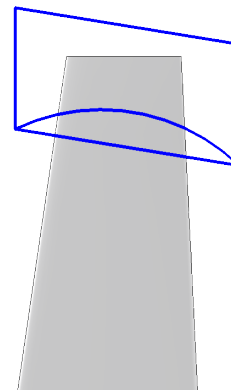
**Fig. 80**



**Fig. 81**

Step 5. Click **3 Point Arc**  (S) in the Arc flyout  on the Sketch toolbar.

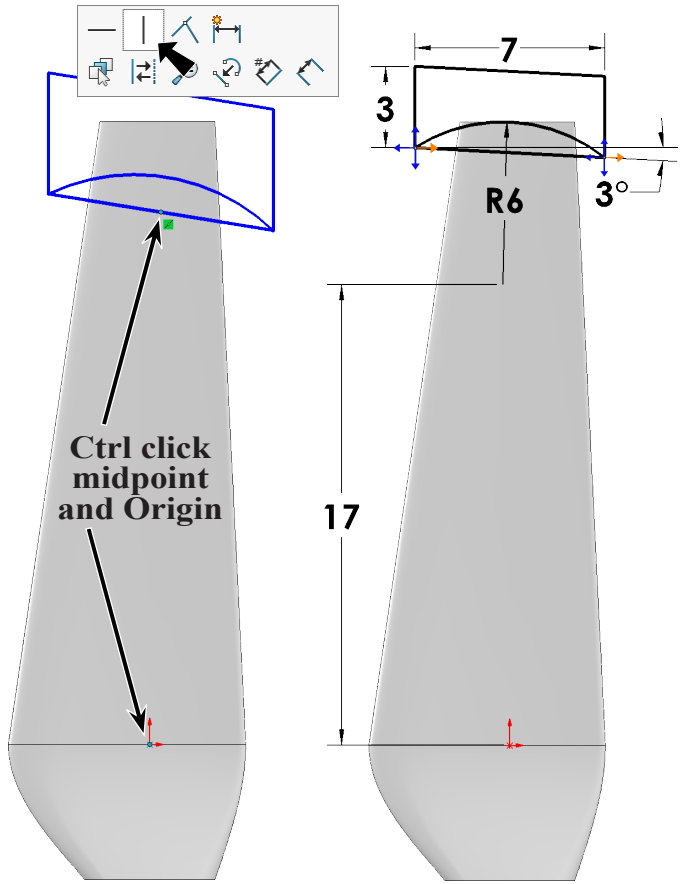
Step 6. Sketch arc across bottom endpoints parallelogram with radius above, **Fig. 82**.



**Fig. 82**

Step 7. **Unselect Arc tool.** To unselect, **right click graphics area and click Select** from menu.

Step 8. **Ctrl click midpoint** of bottom line of parallelogram and **Origin** to select both. Release Ctrl key and click **Make Vertical** on the context toolbar, **Fig. 83.**



Step 9. Click **Smart Dimension** (S) on the Sketch toolbar.

Step 10. Add dimensions, **Fig. 84.** To dimension angle radius, hover over the arc to wake up centerpoint. To dimension angle to imaginary line, click **bottom line of parallelogram and left endpoint of same line**, then click the **right horizontal crosshair** and place dimension.

Step 11. Click **Isometric** on the Standard Views toolbar.

Step 12. Click **Features** on the Command Manager toolbar.

Step 13. Click **Extruded Cut** on the Features toolbar.

Step 14. In Cut-Extrude Property Manager set:

under Direction 1, **Fig. 85**  
 End Condition  
**Through All - Both**  
 under Selected Contours  
 click the **top contour**,  
**Fig. 86**  
 click OK.

Step 15. Save (Ctrl-S).

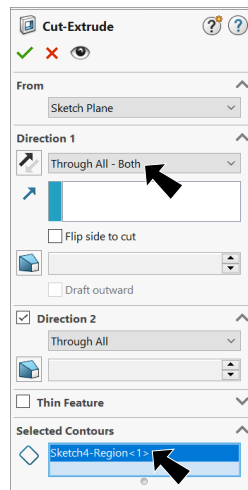


Fig. 85

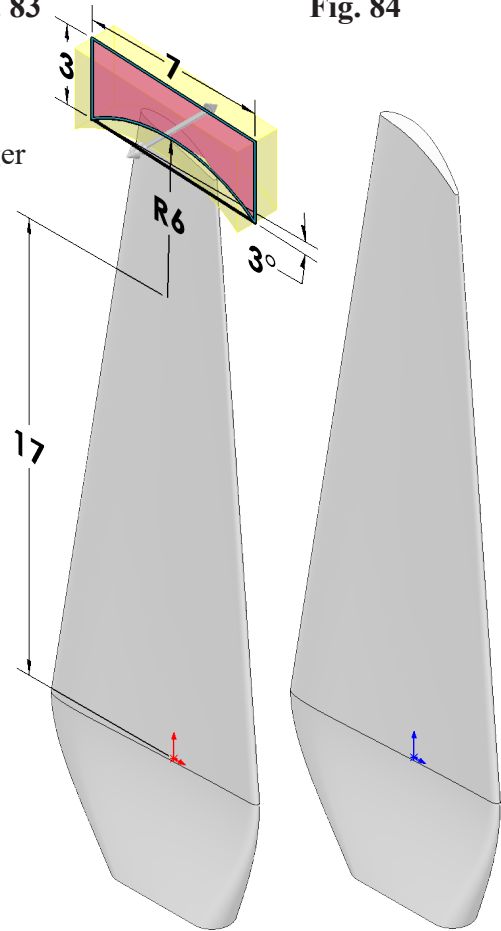


Fig. 86

Fig. 87

## R. Split Tip.

Step 1. Click **Front Plane**  in the Feature Manager and click **Sketch**  on the context toolbar, **Fig. 88**.

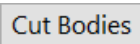


Step 2. Click **Line**  (L) on the Sketch toolbar.

Step 3. Stretch a **horizontal line below tip of blade**, **Fig. 89**.

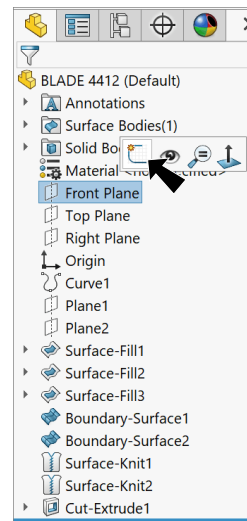
Step 4. Click **Smart Dimension**  (S) on the Sketch toolbar.

Step 5. Add **18.4** dimension, **Fig. 89**.

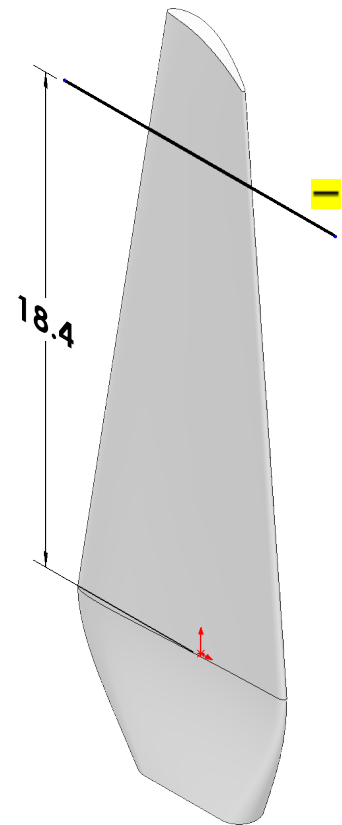
Step 6. Click Insert Menu > Features > Split.

Step 7. In the Split Property Manager:  
 under Trim Tools, **Fig. 90**  
**Sketch5** was preselected  
 click **Cut Bodies**  button  
 under Resulting Bodies  
 click **Select All**   
 uncheck **Consume cut bodies**  
 click OK .

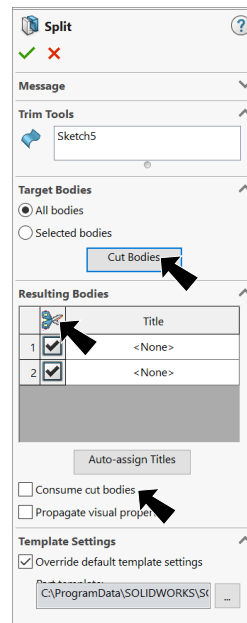
Step 8. Save  (Ctrl-S).



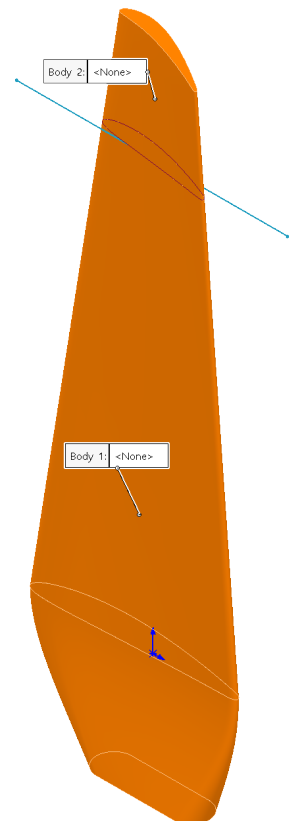
**Fig. 88**



**Fig. 89**









**Fig. 90**

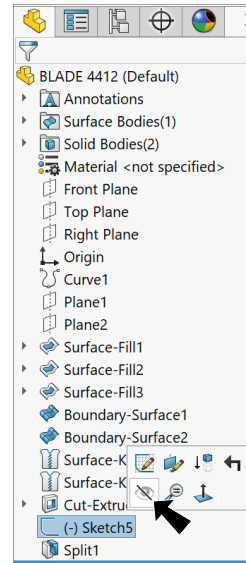


**Fig. 91**

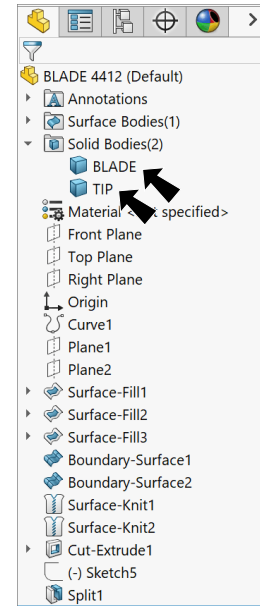
## S. Rename Bodies.

Step 1. **Hide Sketch5** . To hide, click **Sketch4** in the Feature Manager and **Hide**  on the context toolbar, **Fig. 92**.

Step 2. **Rename bodies BLADE**  and **TIP**  **Fig. 93**. To rename, expand **Solid Bodies**  folder in the Feature Manager. Slowly click twice (or use the F2 key) over **Split 1[1]**  and key-in **BLADE**. Repeat and rename **TIP**.



**Fig. 92**

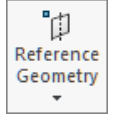



**Fig. 93**




## T. Create Axis.

Step 1. **Ctrl click Front Plane**  and **Right Plane**  feature to select both planes, **Fig. 94**.

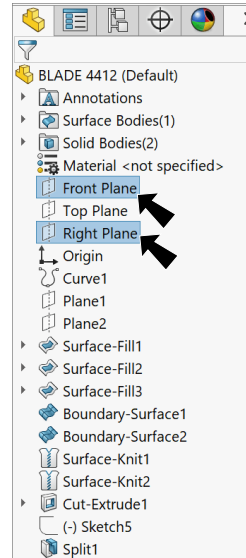
Step 2. Click **Features**  **Features** on the Command Manager toolbar.

Step 3. Click **Reference Geometry**  on the Features toolbar and **Axis**  from the menu.

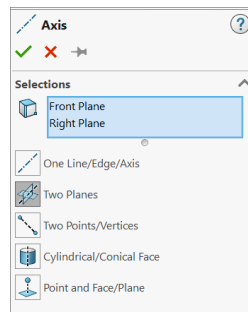
Step 4. In the Axis Property Manager: under Selections, **Fig. 95** **Planes** were preselected click **OK** .

Step 5. **Hide Axis1** . To hide, click **Axis1**  in the Feature Manager and **Hide**  on the context toolbar, **Fig. 97**. The axis will be used later as a mate in the Propeller Assembly.

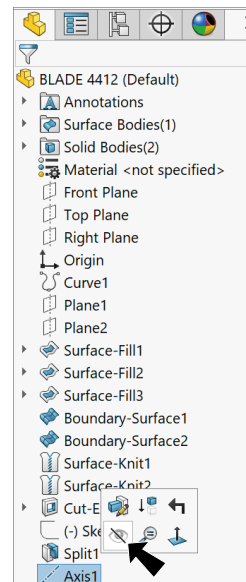
Step 6. Save  (**Ctrl-S**).



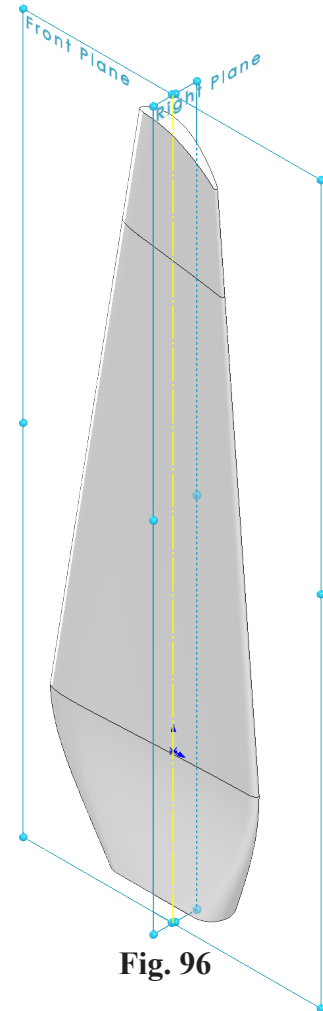
**Fig. 94**



**Fig. 95**



**Fig. 97**



**Fig. 96**

## U. Appearance: Dark and Light Green Satin Titanium.

Step 1. Click the part to select part, click **Appearances Callout**  on the context toolbar and click **BLADE 4412** , Fig. 98.

Step 2. In the Appearances Task pane, expand **Metal**, click **Titanium** and in the lower pane select **satin finish titanium**, Fig. 99.

Step 3. In the Appearances Property Manager set:

under **Color**, Fig. 100

set **RGB values**

**R 98**

**G 114**

**B 119**

click **Keep Visible**  and **OK** . The **Push Pin**  on allows selection of another appearance.

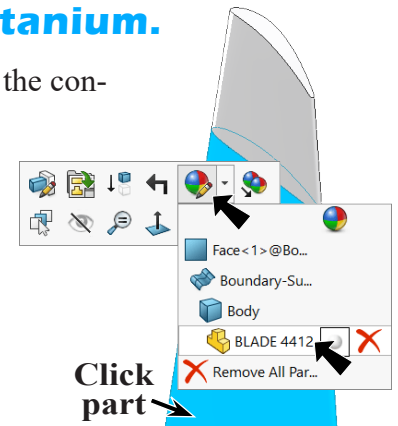


Fig. 98

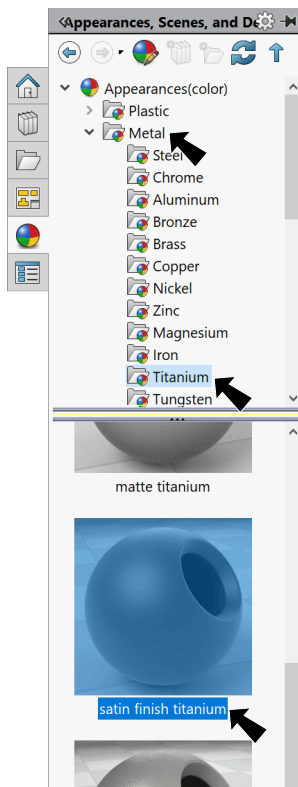


Fig. 99

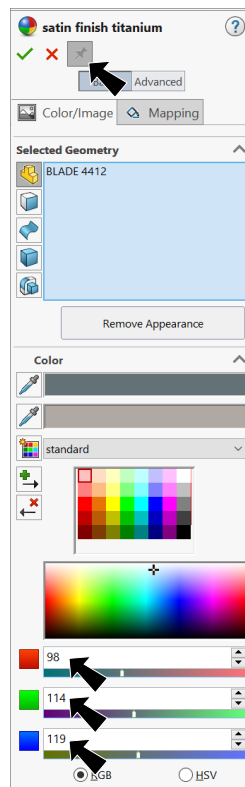


Fig. 100

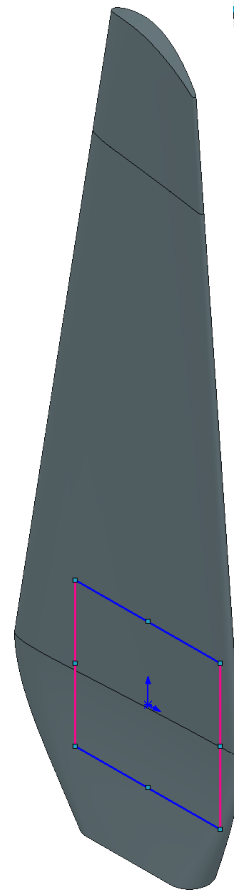


Fig. 101

Step 4. In the Appearances Property Manager set:  
under Selected Geometry

click **Select Bodies** , **Fig. 102**

click **TIP** , **Fig. 103**

under Color

set **RGB** values

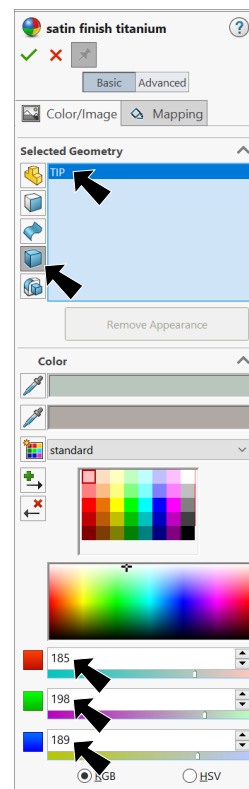
**R 185**

**G 198**

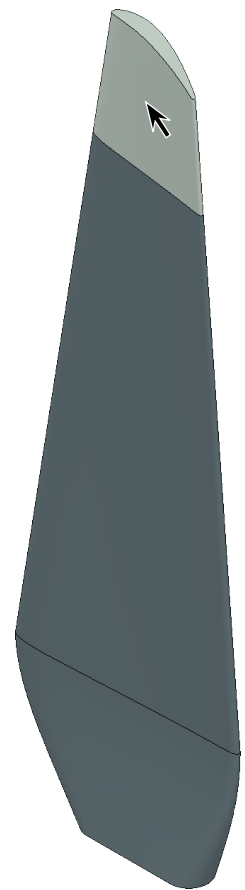
**B 189**

click **OK**  and click **Cancel** .

Step 5. Save  (**Ctrl-S**).



**Fig. 102**



**Fig. 103**