

CO2 Rail Car E Flow Sim

A. Enable Flow Simulation.

Step 1. If necessary, open your ASSEMBLY file.

Step 2. If necessary, turn on Flow Simulation, click the flyout of Options



on the Standard toolbar and click Add-Ins.

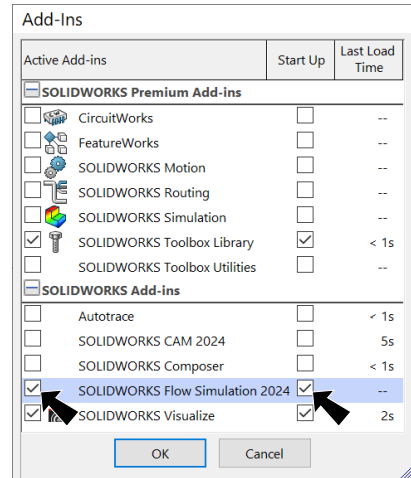
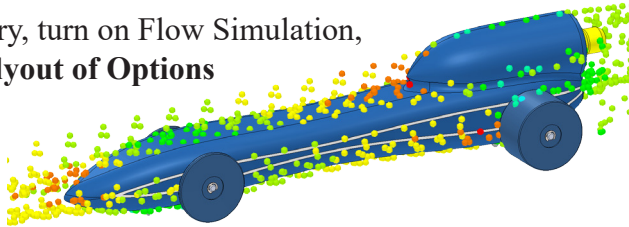

Fig. 1

Step 3. In the dialog box, scroll down to **Flow Simulation** and place a check in the check box under **Active Add-Ins** and **Start-Up**, Fig. 1. Click OK.

B. Create Project.

Step 1. Click **Flow Simulation** tab **Flow Simulation** on the Command Manager toolbar.

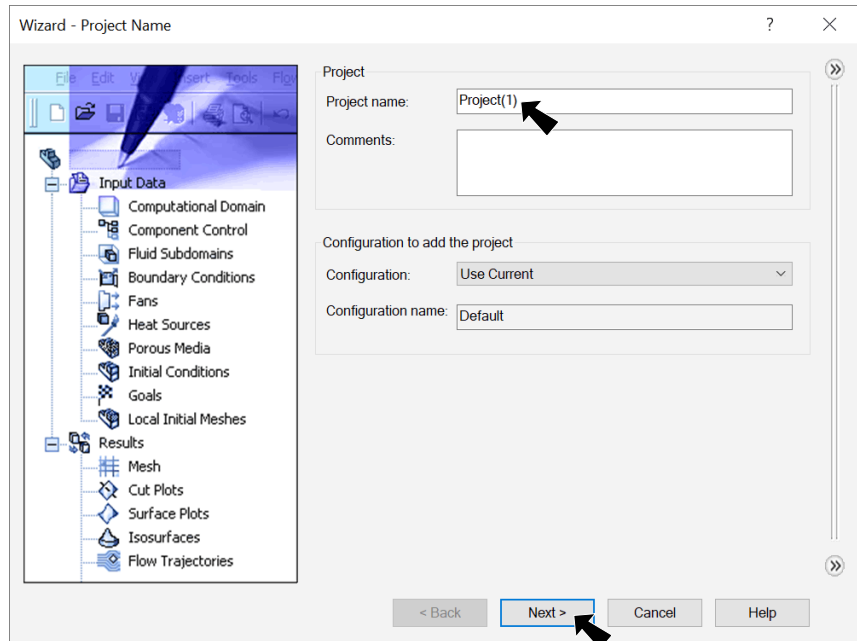

Fig. 2

Step 2. Click **Wizard** **Wizard** on the Flow Simulation toolbar.

Step 3. Use **Project(1)** for Project name, Fig. 2.

Step 4. Click Next.

Step 5. **Unit System:** Select **SI (m-kg-s)** for Unit system, Fig. 3.

Step 6. Under Parameter, set **Velocity** units to **Mile/ hour**, Fig. 3.

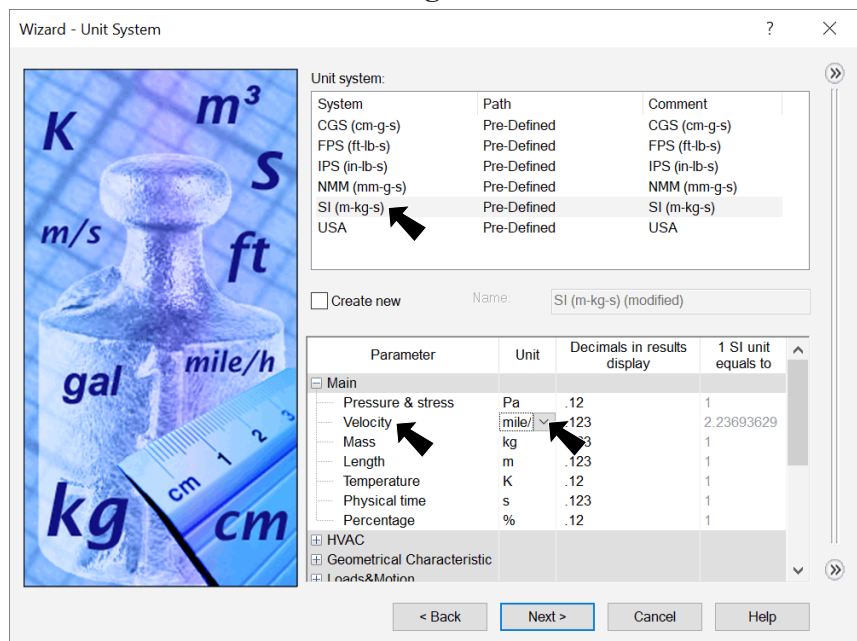

Fig. 3

Step 7. Scroll down Parameters, expand **Loads & Motion** and set Force units to **Gram force**, Fig. 4. Gram force unit is p.

Step 8. Click Next.

Step 9. **Analysis Type:** Under Analysis type, select **External**, Fig. 5.

Step 10. Check **Exclude cavities without flow conditions**
Check **Exclude internal space**, Fig. 5.

Step 11. Click Next.

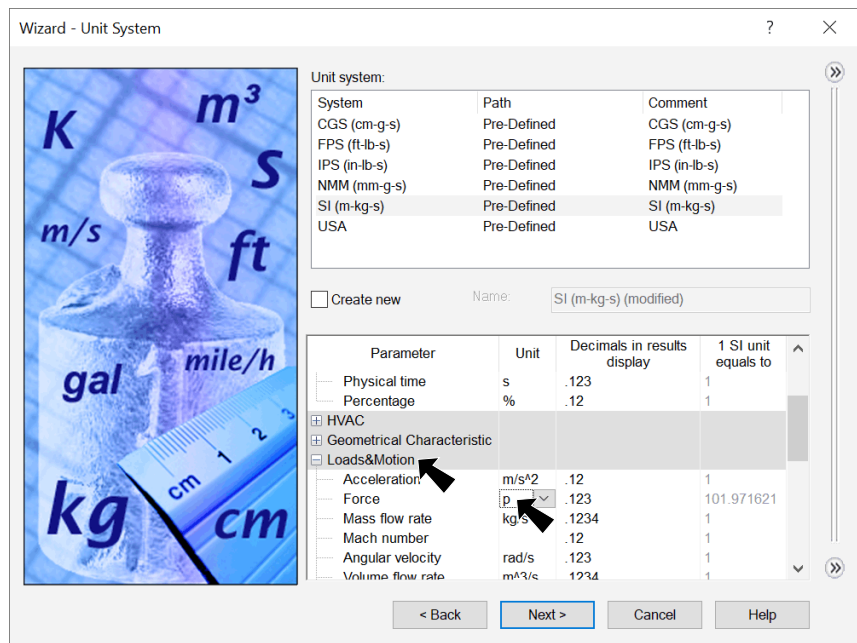

Fig. 4

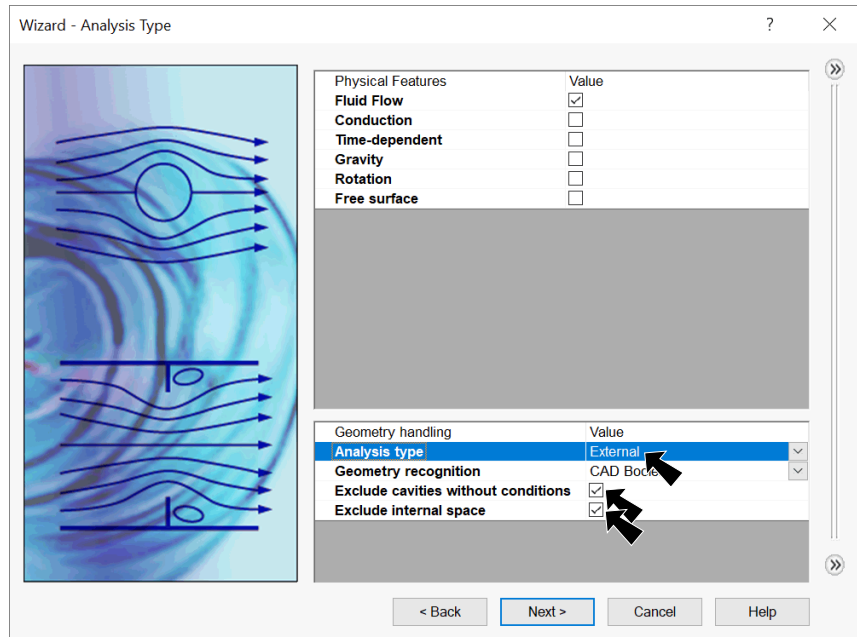

Fig. 5

Step 12. **Default Fluid:**
Expand Gases, select **Air** and click **Add**, **Fig. 6**.

Step 13. Click Next.

Step 14. **Wall Conditions:**
Use the default values for wall condition, **Fig. 7**.

Step 15. Click Next.

Step 16. **Initial Conditions:**
Under Velocity parameters set **Velocity in Z direction to -75 Mile/h**, **Fig. 8**. (click and key-in -75).

Step 17. Click Finish.

Tip: Good idea to turn off decals. View Menu > Hide\Show > Decals.

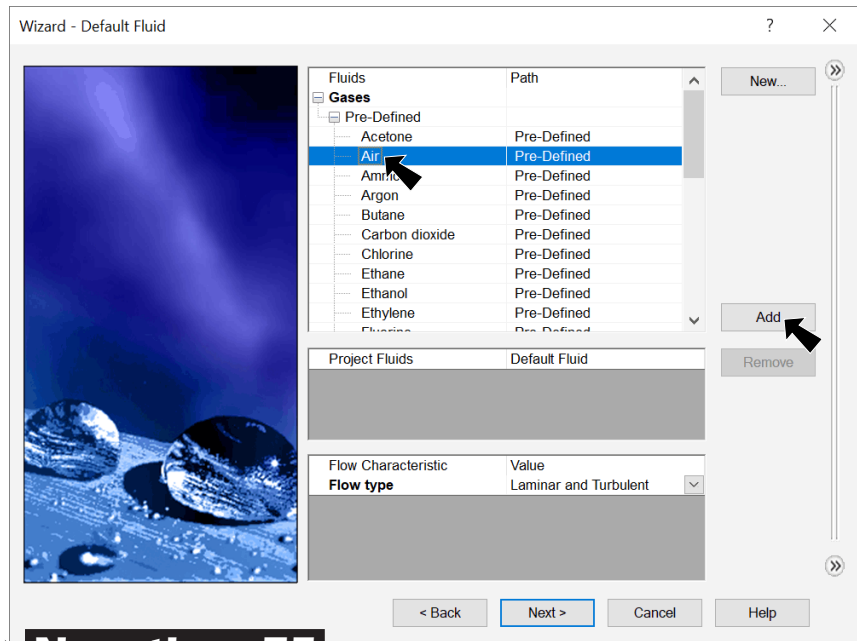

Negative -75

Fig. 6

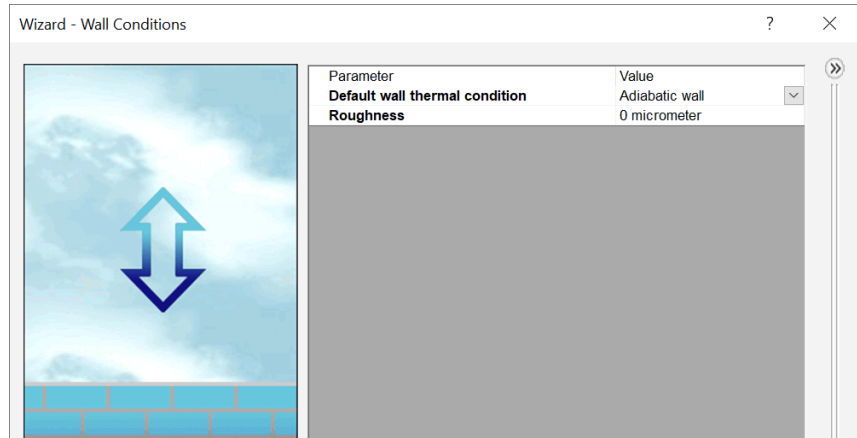
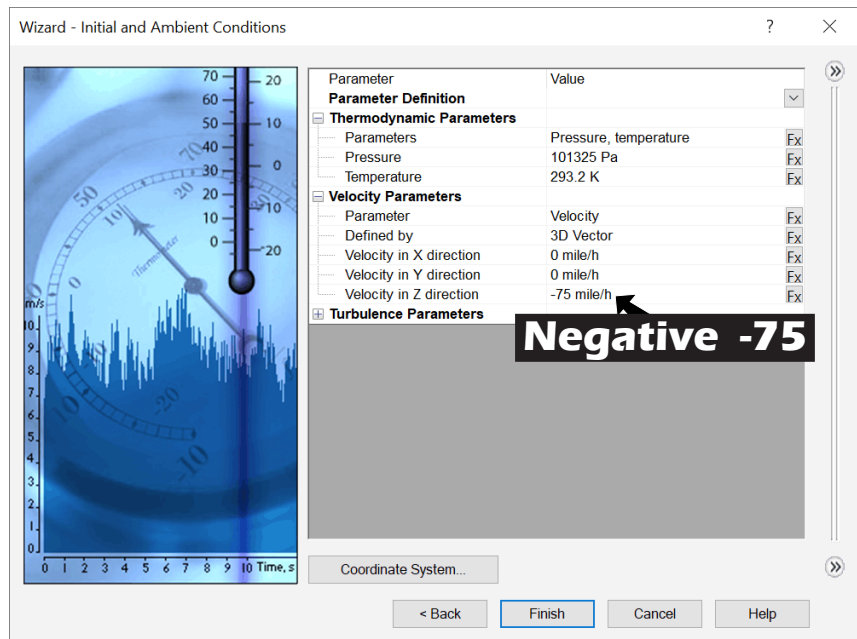



Fig. 7









Negative -75

Fig. 8

C. Computational Domain.

Step 1. Click **Computational Domain**  on the Flow Simulation toolbar.

Step 2. In the Computational Domain Property Manager:
set values, **Fig. 9**

 X max .15
 X min -0.15 ← **Negative**
 Y max .2
 Y min -0.02 ← **Negative**
 Z max .3
 Z min -0.4 ← **Negative**

click OK .

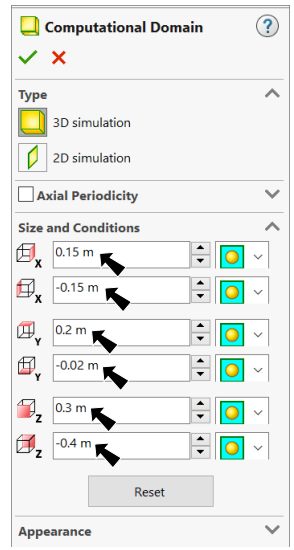

Fig. 9

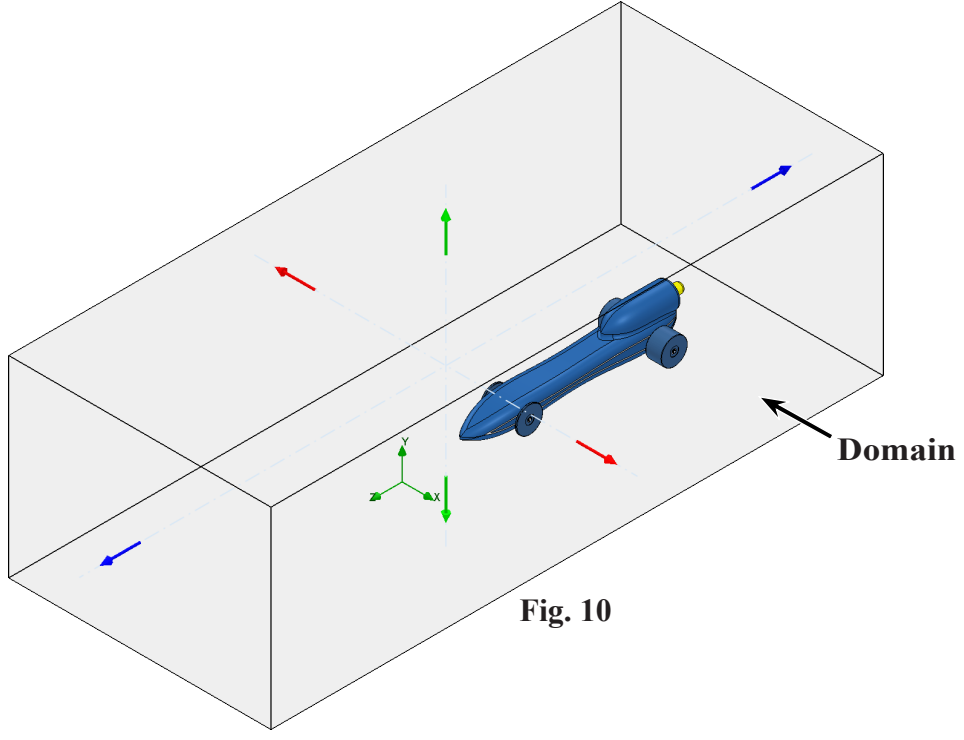
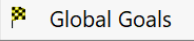
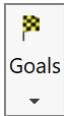

Fig. 10

D. Insert Global Goals.

Step 1. Click **Global Goals**  in the **Goals flyout**



on the Flow Simulation toolbar.

Step 2. Drag the edge of the Feature Manager to the right to expand, **Fig. 11**.

Step 3. In the Global Goals Property Manager:
scroll down the Parameters to **Force (Y)**, **Fig. 11**
and **check:**

Force (Y)

Force (Z)

click OK .

Step 4. Rename the goals to **Lift** and **Drag**. To rename, click **Force (Y)**, press **F2** key and key-in **Lift**, **Fig. 13**. Rename **Force (Z)** to **Drag**.

Step 5. Save  (Ctrl-S).

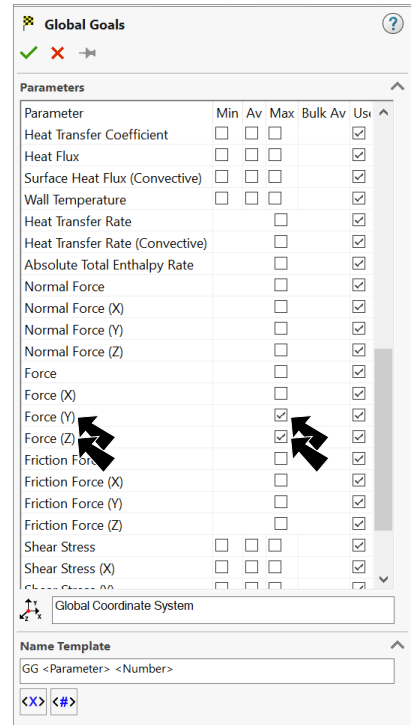

Fig. 11

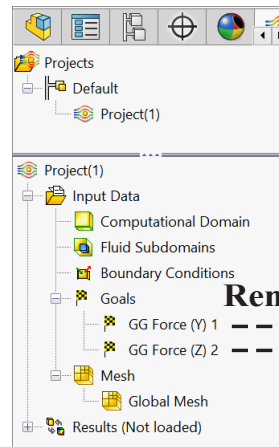

Fig. 12

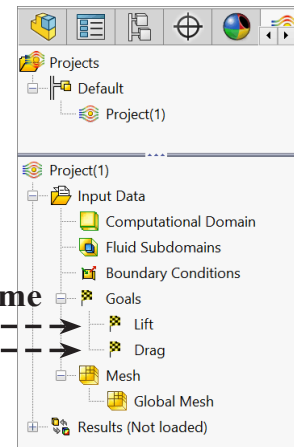



Fig. 13

E. Run Analysis.

Step 1. Click **Run**  on the Flow Simulation toolbar.

Step 2. Click **Run** in the Run dialog box, **Fig. 14**.

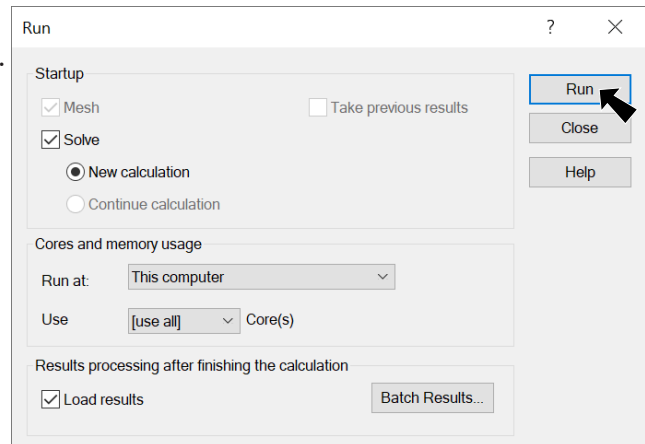

Fig. 14

F. Solver.

Step 1. In the Solver dialog box you can view Calculation time left, **Fig. 15**. The CPU time runs around 1-2 minutes depending design and computer.

Step 2. When the calculation is done view the drag in the Solver, click Insert Menu > Goal Table, **Fig. 16**. Our drag was **-66.59**.

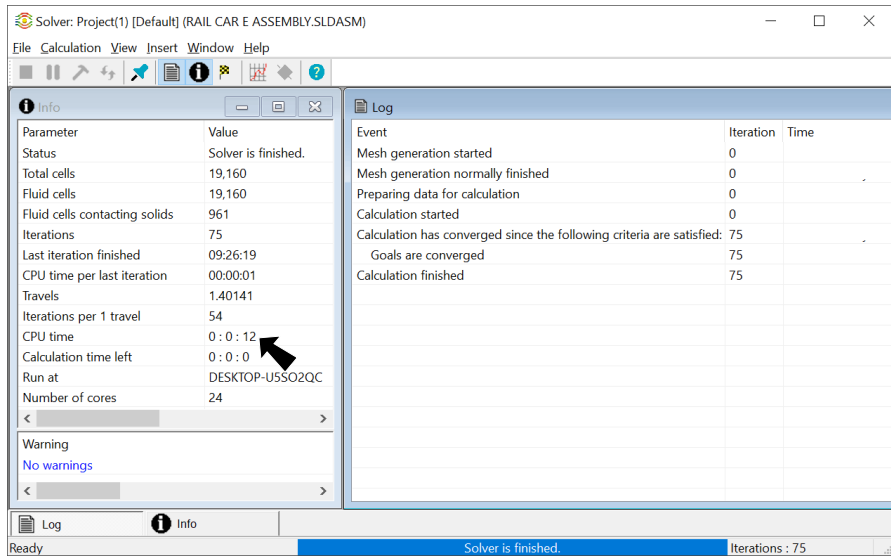

Fig. 15

Step 3. Close Solver dialog box .

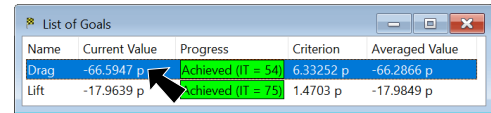

Fig. 16

G. Surface Plots.

Step 1. Right click **Computational Domain** in Flow Simulation tree and click **Hide**, **Fig. 17**.

Step 2. Click **Surface Plot** in the **Insert** flyout



on the Flow Simulation toolbar.

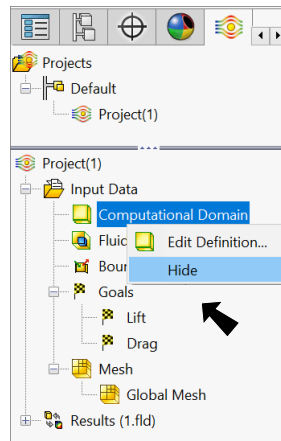

Fig. 17

Step 3. In the Surface Plot Property Manager set: under Selection, **Fig. 18**

check **Use all faces**
under Display
select **Contours**
under Contours

click **Adjust Minimum and Maximum**

101575 for **Maximum** pressure

100930 for **Minimum** pressure

click **OK** .

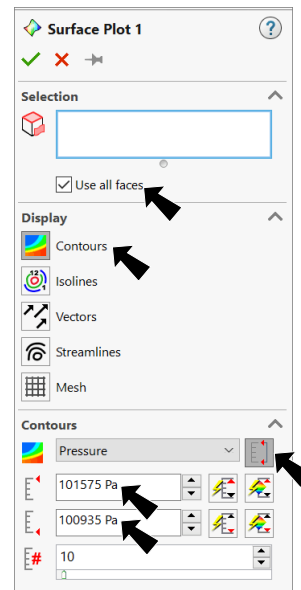

Fig. 18

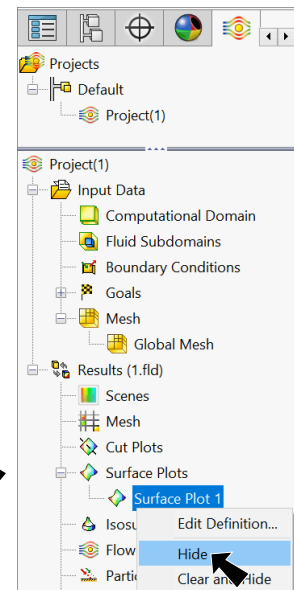

Fig. 20

Step 4. After viewing the Surface Plot, expand **Results** in Flow Simulation tree and expand **Surface Plots**. Right click **Surface Plots 1** and click **Hide**, **Fig. 20**.

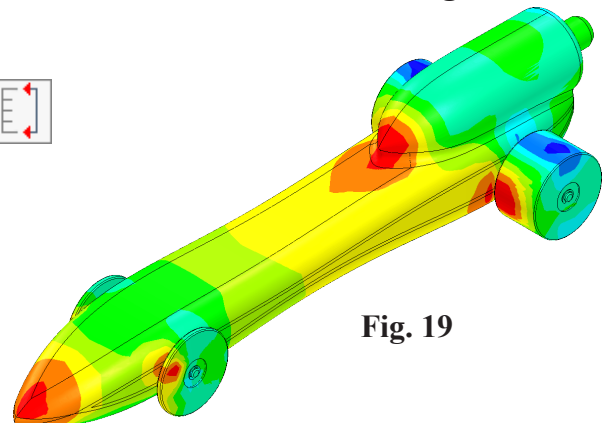



Fig. 19

H. Flow Trajectories.

Step 1. Click **Flow Trajectories**  **Flow Trajectories** in the **Insert flyout**  on the Flow Simulation toolbar.

Step 2. In the Flow Trajectories Property Manager:
under Starting Points, **Fig. 21**
in the selection box

Drag a selection to left to select only the Body, Fig. 22

Number of Points  **# 50**

under Appearance

Draw Trajectories As  **Arrows**

Arrow Size  **.002**

click OK .

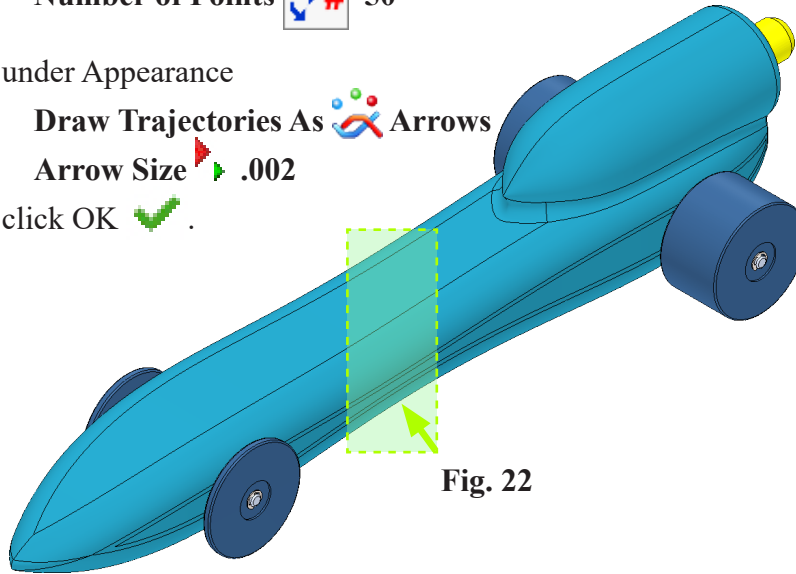

Fig. 22

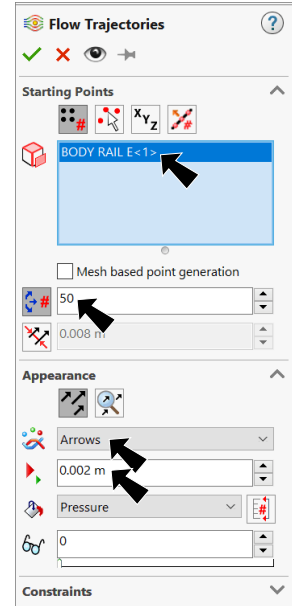

Fig. 21

Step 3. After viewing the flow trajectories, **right click Flow Trajectories 1** in Flow Simulation tree and click **Hide**, **Fig. 24**.

Step 4. Save  (**Ctrl-S**).

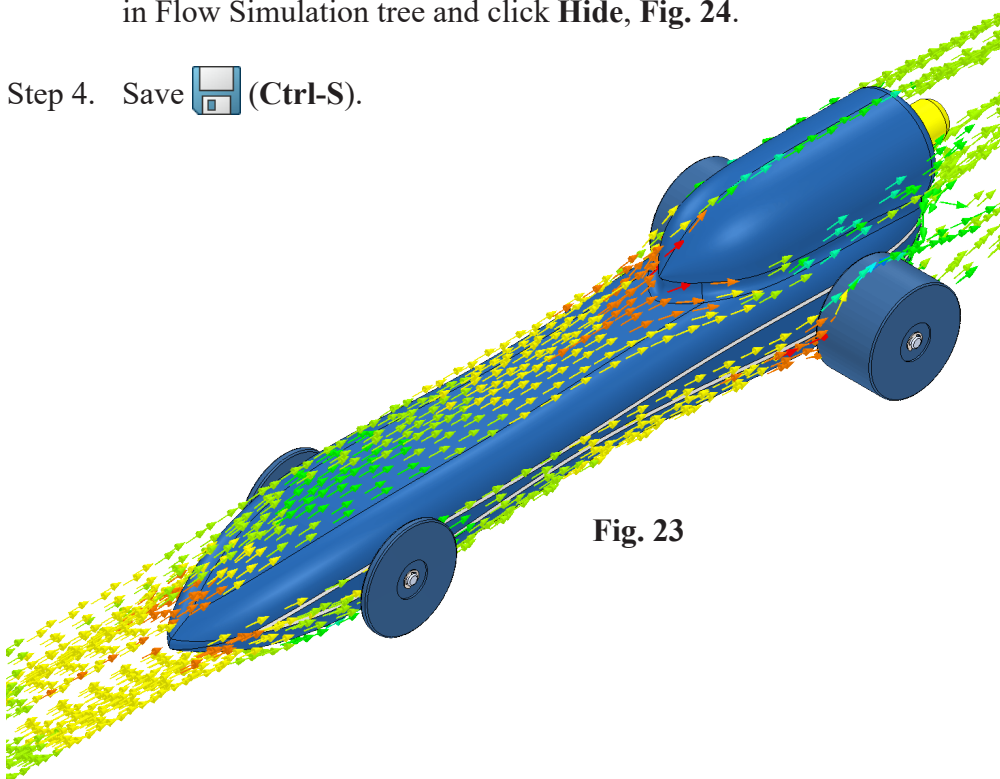

Fig. 23

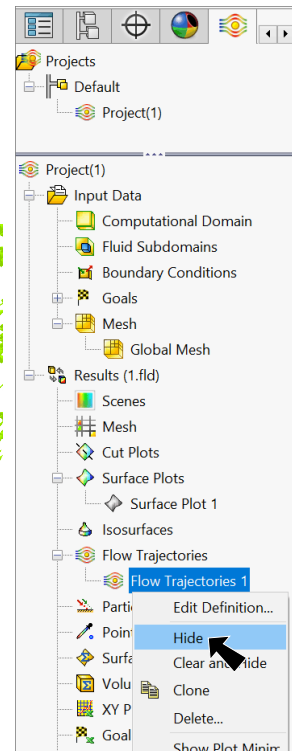

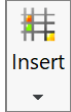

Fig. 24

I. Goal Plot.

Step 1. Click **Goal Plot**  in the **Insert flyout**  on the Flow Simulation toolbar.

Step 2. In the Goal Plot Property Manager:
 under Goals, **Fig. 25**
 check **All**
 under Options

click **Export to Excel** 

An Excel file is opened. Note the Drag, **Fig. 26**.
 Click the **Drag tab** at the bottom of the Excel file to view
 chart, **Fig. 26**.
 Close Excel file.

Click OK .

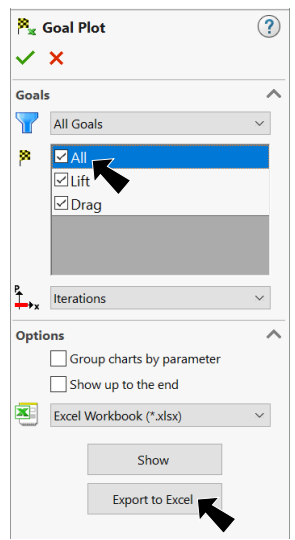

Fig. 25

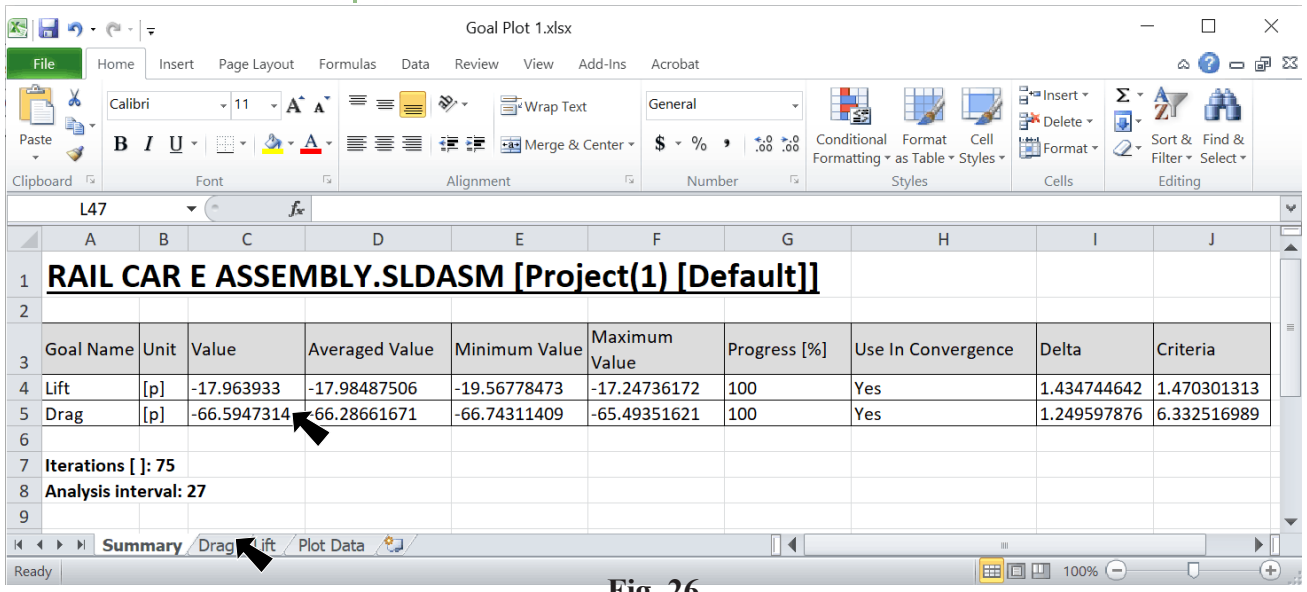

Fig. 26

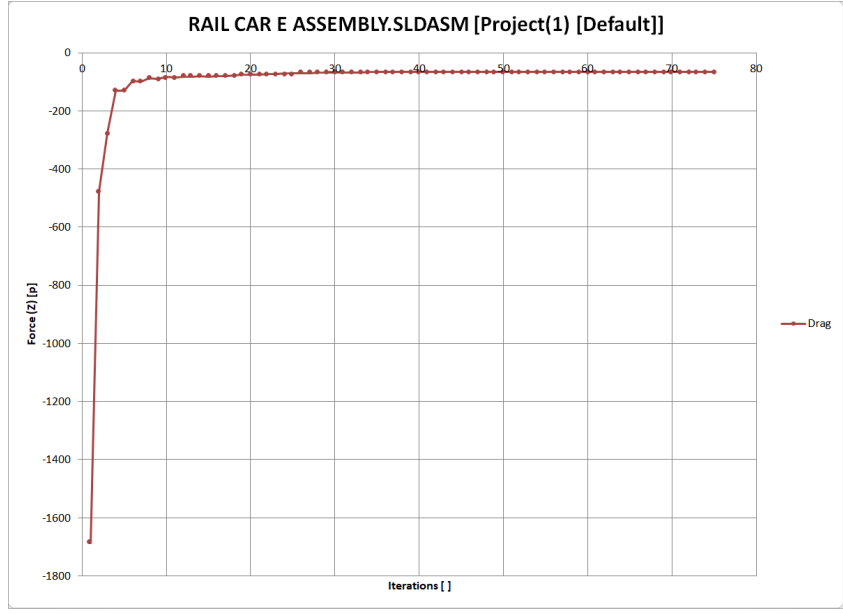





Fig. 27

J. Animate Flow Trajectories.

- Step 1. Click **Right**  on the Standard Views toolbar. (Ctrl-4)
- Step 2. **Right click** **Flow Trajectories 1** in Flow Simulation tree and click **Animation**, Fig. 28.
- Step 3. If necessary, **Expand**  to expand the panel at the bottom right of the display in the animation control panel, Fig. 29.
- Step 4. Click **Play**  in animation control panel, Fig. 29.
- Step 5. **Right click** **Flow Trajectories 1** in the Animation tree and click **Edit Definition**, Fig. 29.
- Step 6. In the Flow Trajectories Property Manager:
 - under Appearance,

Draw Trajectories As  **Spheres**
Width  **.003**
 click **OK**  .

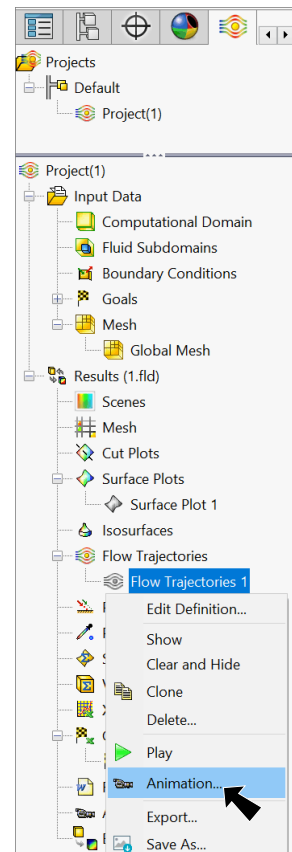

Fig. 28

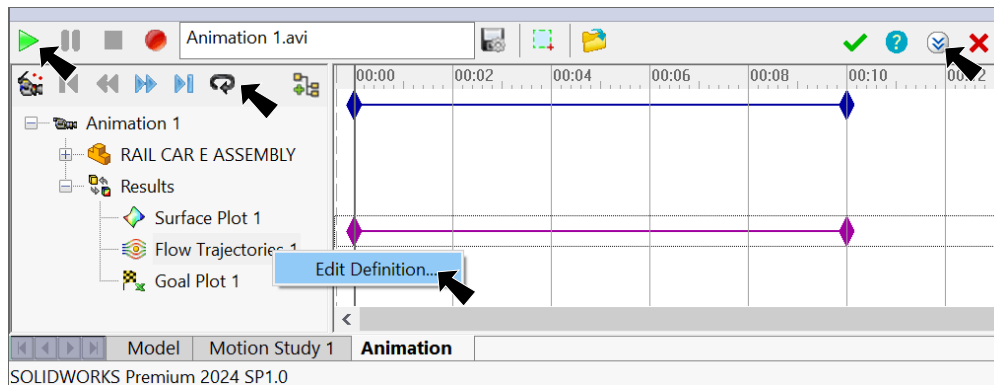





Fig. 29

- Step 7. Click **Loop**  and **Play**  in animation control panel, Fig. 29.
Click **Stop** .

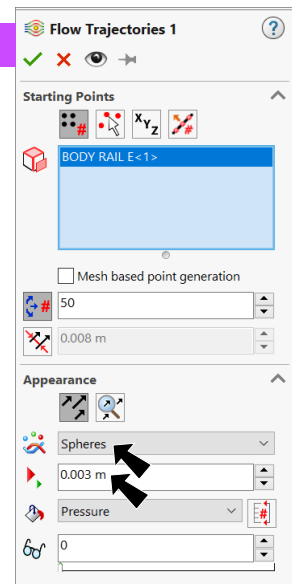

Fig. 30

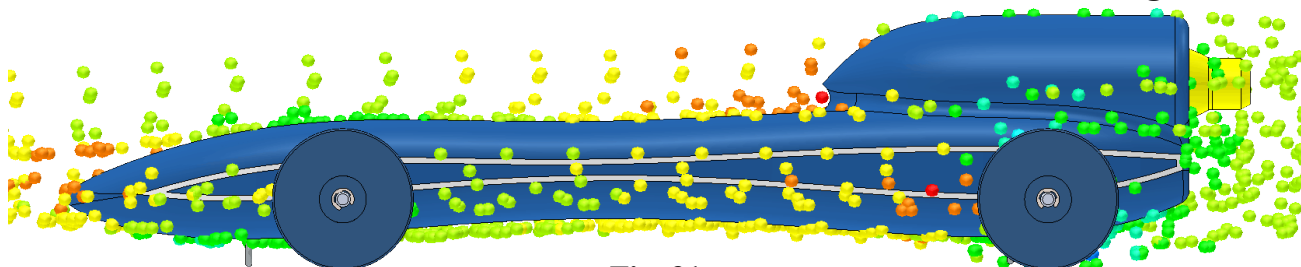

Fig. 31

K. Create Animation Movie.

Step 1. Click **Isometric**  on the Standard Views toolbar. (Ctrl-7)

Step 2. In the Animation control panel turn on **Capture Region** , Fig. 32.

Step 3. Drag the red frame capture region in graphics area to resize/move capture region, Fig. 33.

Step 4. Click **Record** , Fig. 32.

Step 5. Click **Open Folder**  to view Animation AVI file.

Step 6. To exit, click **OK**  in Animation control panel.

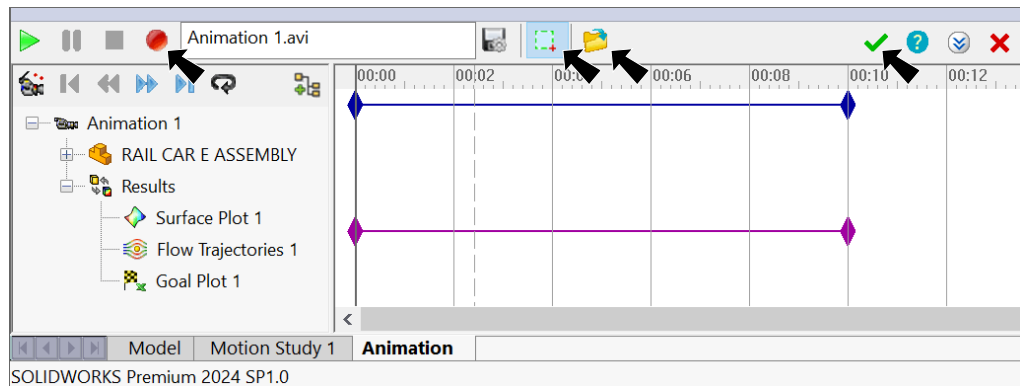

Fig. 32

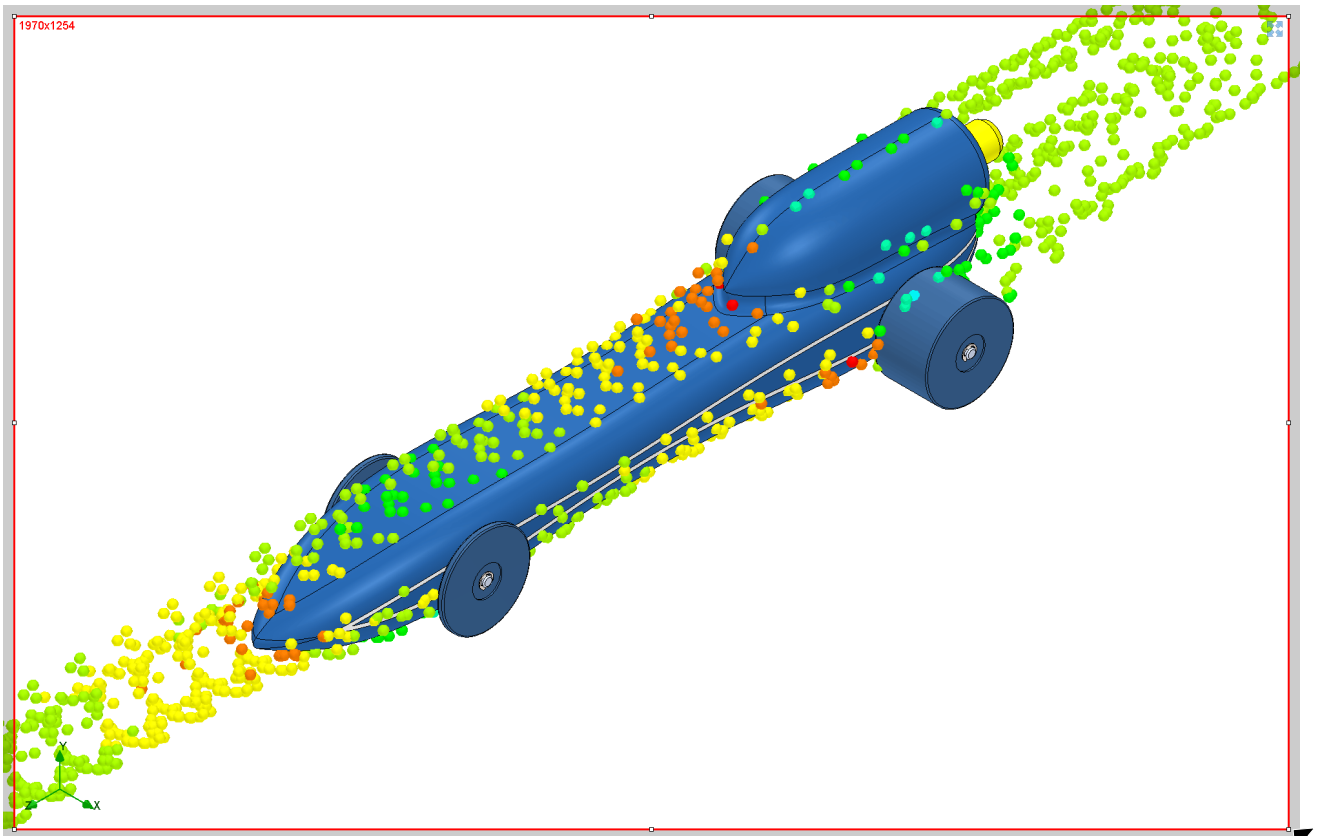

Fig. 33