

CO2 Shell Car Axle Retainer

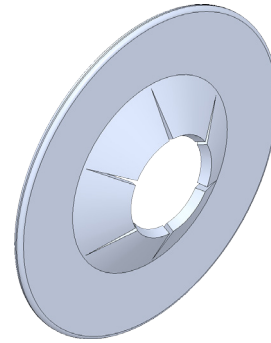

A. Revolve Thin Feature.

Step 1. Click File Menu > New, click **Part Metric** and OK.

Step 2. Click **Front Plane** in the Feature Manager and click **Sketch** from the context toolbar, **Fig. 1**.

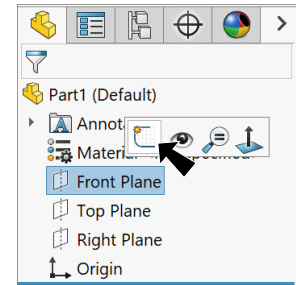

Fig. 1

Step 3. Click **Line** (L) on the Sketch toolbar.

Step 4. Sketch a line starting directly above the Origin but do not sketch the line to the Origin, **Fig. 2**. Sketch a second line from bottom endpoint of first line at angle to the right. Do not bring the angle line down to Origin.

Step 5. Click **Smart Dimension** (S) on the Sketch toolbar.

Step 6. Add dimensions, **Fig. 3**.

Step 7. Click **Centerline** in the **Line flyout** on the Sketch toolbar.

Step 8. Sketch a **horizontal centerline** from the Origin, **Fig. 4**.

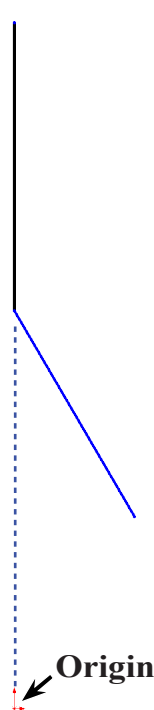

Fig. 2

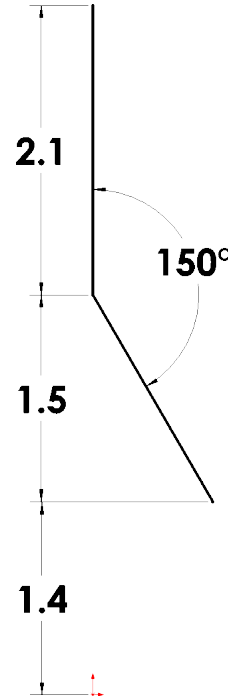

Fig. 3

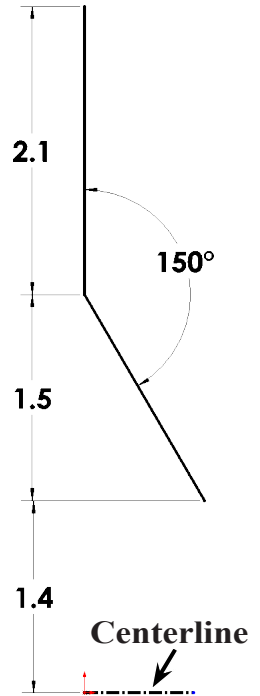
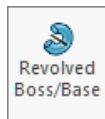

Fig. 4

Step 9. Click **Features** on the Command Manager toolbar.

Step 10. Click **Revolved Boss/Base** on the Features toolbar.



Step 11. Click **No** to automatically close sketch, **Fig. 5**.

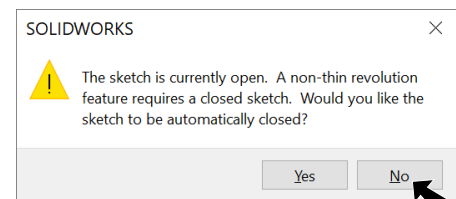

Fig. 5

Step 12. Click **Front**  on the Standard Views toolbar. (Ctrl-1)

Step 13. In the Revolve Property Manger set:
under Thin Feature, **Fig. 6**

click **Reverse direction** 

Thin feature should be to **right of sketch**, **Fig. 7**
if in opposite direction, click Reverse

direction 

Direction 1 Thickness  **.3**

click OK .

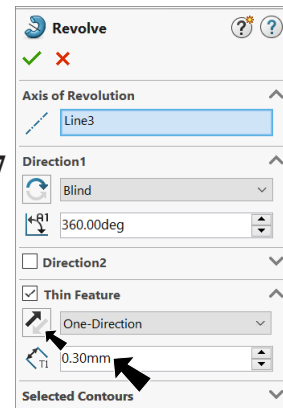

Fig. 6

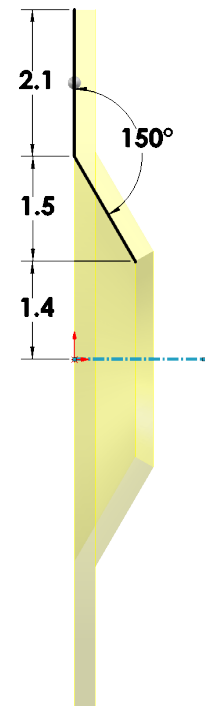

Fig. 7

B. Save as "AXLE RETAINER".

Step 1. Click File Menu > Save As.

Step 2. Key-in **AXLE RETAINER** for the filename and press ENTER.

C. Cut.

Step 1. Click **Right Plane**  in
the Feature Manager and
click **Sketch**  on the
content toolbar, **Fig. 8**.

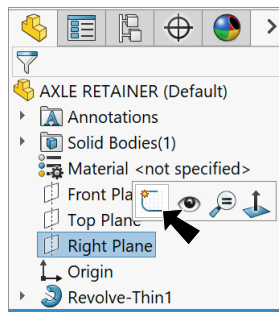

Fig. 8

Step 2. Click **Left**  on the
Standard Views toolbar.
(Ctrl-3)

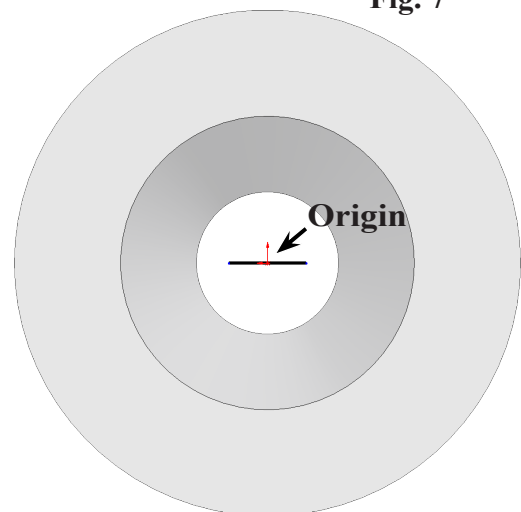



Fig. 9

Step 3. Click **Midpoint Line**  in the **Line flyout**
 on the Sketch toolbar.

Step 4. Sketch a horizontal line out from the Origin , **Fig. 9**.

Step 5. Click **Line**  (L) on the Sketch toolbar.

Step 6. Sketch line up to edge of body and back to other
endpoint of horizontal line, **Fig. 10**.

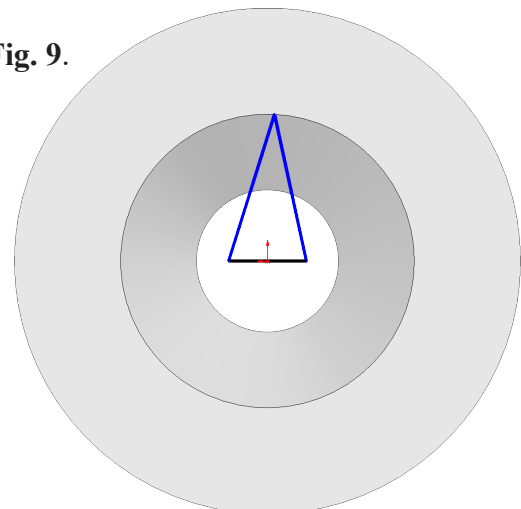

Fig. 10

Step 7. **Unselect Line tool.** To unselect, **right click graphics area and click Select** from menu.

Step 8. **Ctrl click top endpoint of line and Origin** to select both. Release Ctrl key and click **Make Vertical** on the context toolbar, **Fig. 11.**

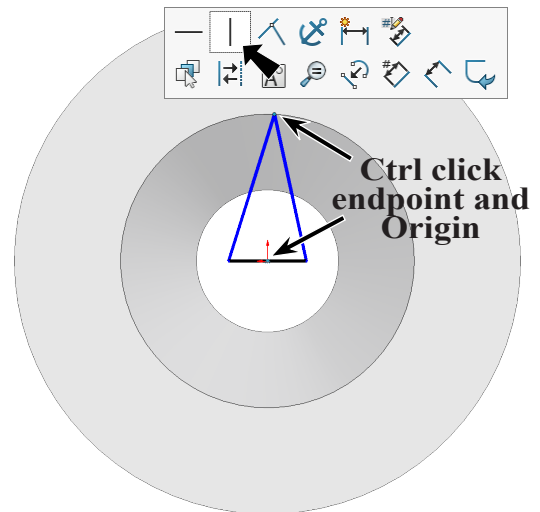

Fig. 11

Step 9. Click **Smart Dimension** (S) on the Sketch toolbar.



Step 10. Dimension horizontal line **.3**, **Fig. 12.**

Step 11. Click **Isometric** on the Standard Views toolbar. (**Ctrl-7**)



Step 12. Click **Features** on the Command Manager toolbar.



Step 13. Click **Extruded Cut** on the Features toolbar.

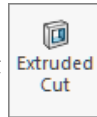

Step 14. In the Cut-Extrude Property Manager set:
under Direction 1, **Fig. 13**

End Condition **Through All**

click **Reverse Direction**



Direction arrow should point to right, **Fig. 14**

click OK ✓.

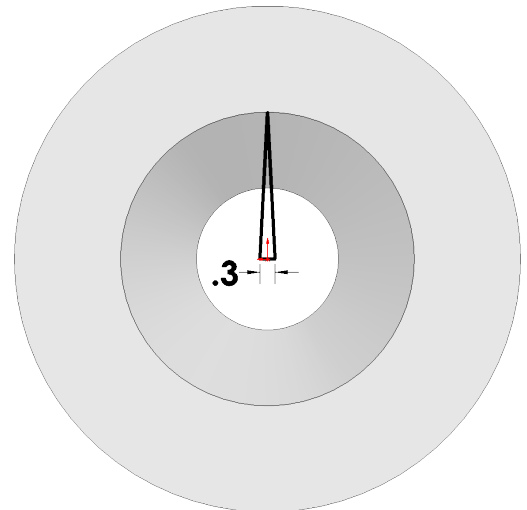

Fig. 12

Step 15. Save (Ctrl-S).

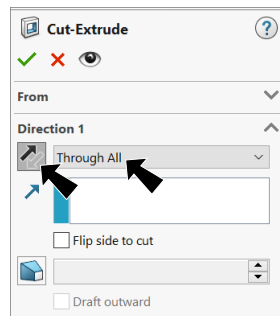

Fig. 13

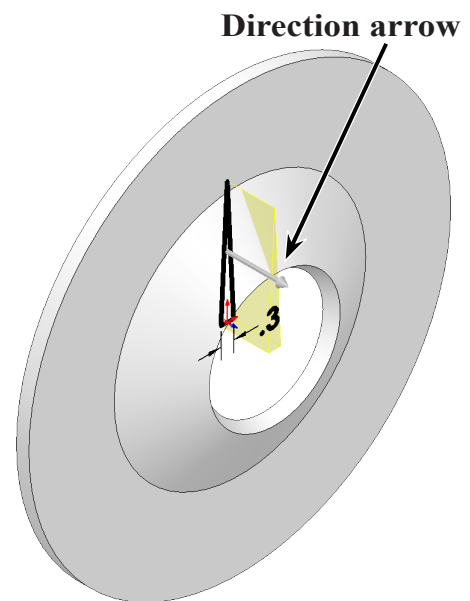
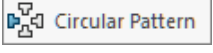





Fig. 14

D. Circular Pattern.

Step 1. Click **Circular Pattern**  in the **Linear Pattern** flyout  on the Features toolbar.

Step 2. In the Circular Pattern Property Manager set:
 under Features and Faces, **Fig. 15**
 click **Cut-Extrude1** in graphics area, **Fig. 16**
 under Direction 1
 click in **Pattern Axes** box **Axis**
 click a **cylindrical face**
 select **Equal spacing**
Number of Instances  **6**
 click OK .

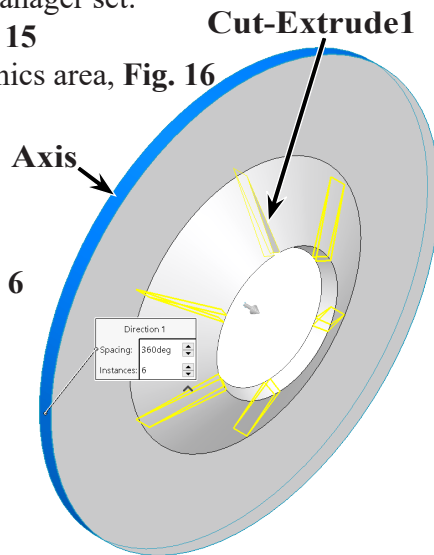

Fig. 16

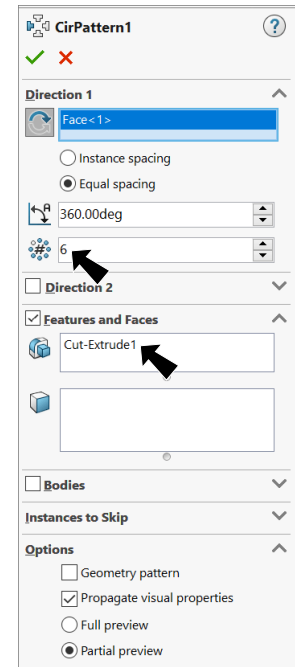



Fig. 15

E. Fillet.

Step 1. Click **Fillet**  on the Features toolbar.

Step 2. In the Fillet Property Manager:
 select **FilletXpert**, **Fig. 17**
Radius  **.13**
 click **outside cylindrical face**,
Fig. 18
 click OK .

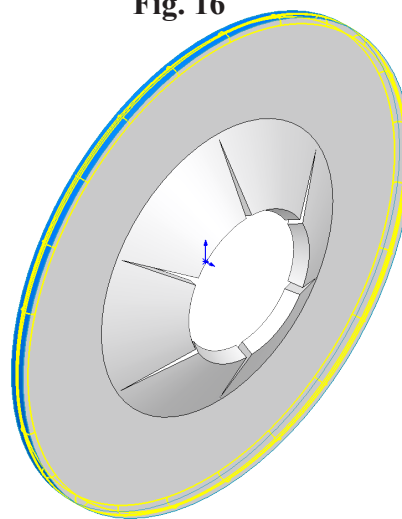

Fig. 18

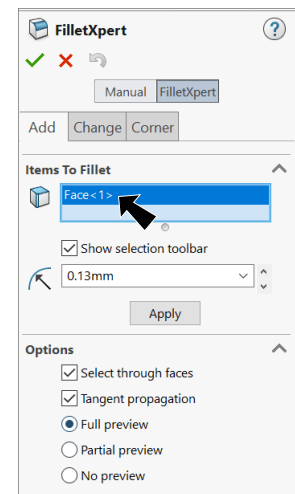



Fig. 17

F. Material Aluminum.

Step 1. **Right click** **Material**  in the Feature Manager and click **Edit Material**.

Step 2. Expand **Aluminum Alloys** in the material tree and select **1060 Alloy**. Click **Apply** and **Close**.

Step 3. Save  (Ctrl-S).

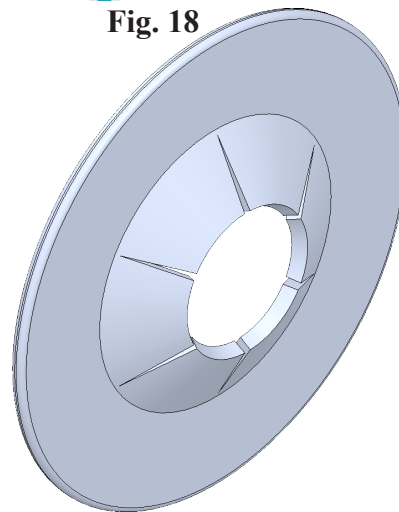

Fig. 19