



CO₂ Rail Car Front Rim Lx



A. Sketch Construction Lines.

Step 1. Click File Menu > New, click **Part Metric** and OK.

Step 2. Click **Front Plane**  in the Feature Manager and click **Sketch**  on the context toolbar, **Fig. 1**.

Step 3. Click **Centerline**  in the **Line flyout**  on the Sketch toolbar.

Step 4. Starting at the Origin , sketch a vertical centerline up and a horizontal construction line out to the left from the top endpoint of centerline, **Fig. 2**. Use the inferencing line, the dotted line that appears when you sketch.

Step 5. Click **Smart Dimension**  (S) on the Sketch toolbar.

Step 6. Dimension the centerline **13.3** and horizontal construction line **1.8**, **Fig. 2**.

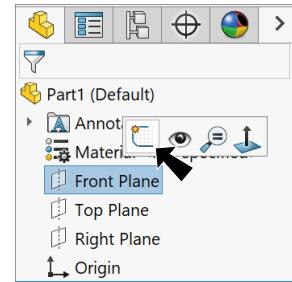
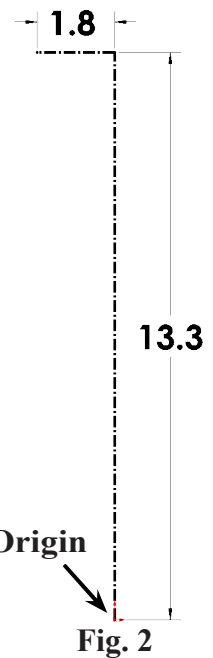

Fig. 1



B. Save as "FRONT RIM LX".

Step 1. Click File Menu > Save As.

Step 2. Key-in **FRONT RIM LX** for the filename and press ENTER.

C. Sketch Lines.

Step 1. Click **Line**  (L) on the Sketch toolbar.

Step 2. Sketch the **three lines**, **Fig. 3**.

Step 3. Click **Smart Dimension**  (S) on the Sketch toolbar.

Step 4. Add dimensions, **Fig. 4**.

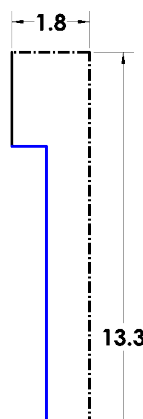

Fig. 3

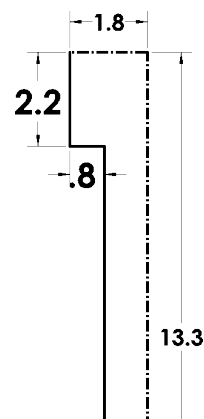

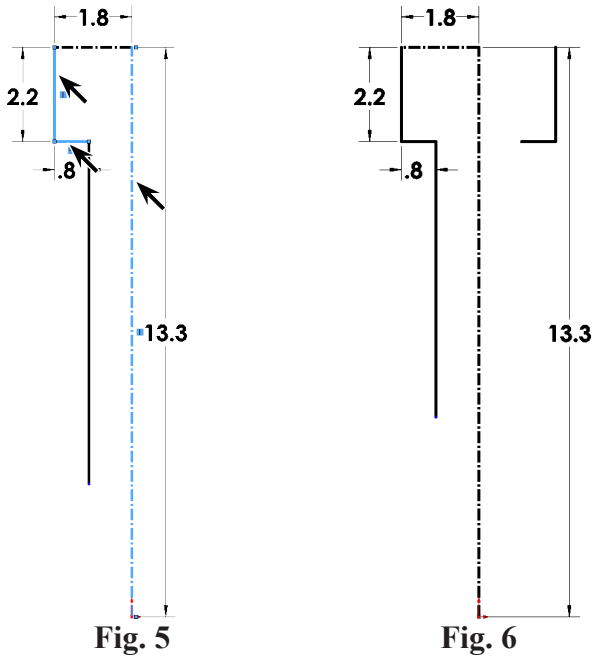





Fig. 4

D. Mirror Sketch.

- Step 1. **Unselect Smart Dimension.** To unselect, **right click graphics area and click Select**  from menu.
- Step 2. **Ctrl click short vertical line, short horizontal line and centerline, Fig. 5.**
- Step 3. Click **Mirror Entities**  **Mirror Entities** on the Sketch toolbar, **Fig. 6.**



E. 3 Point Arc.

- Step 1. Click **3 Point Arc**  (S) in the **Arc flyout**  on the Sketch toolbar.
- Step 2. Sketch an arc between the Position 1, Position 2 and Position 3 in **Fig. 7.** To sketch the arc, first click Position 1, then Position 2. Swing the arc down to Position 3 and click.
- Step 3. Click **Smart Dimension**  (S) on the Sketch toolbar.
- Step 4. Dimension arc **5, Fig. 8.**

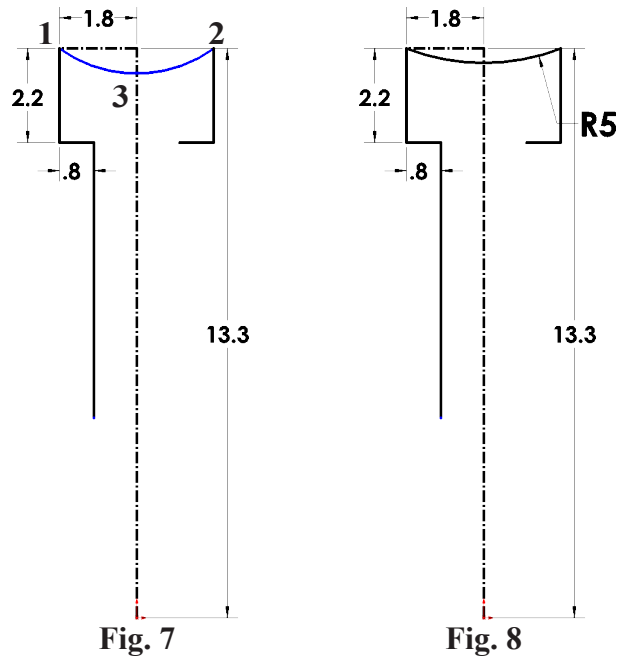

F. Lines Inside Rim.

Step 1. Click **Line**  (L) on the Sketch toolbar.

Step 2. Sketch the **three lines**, **Fig. 9**.

Step 3. Click **Smart Dimension**  (S) on the Sketch toolbar.

Step 4. Add dimensions, **Fig. 10**.

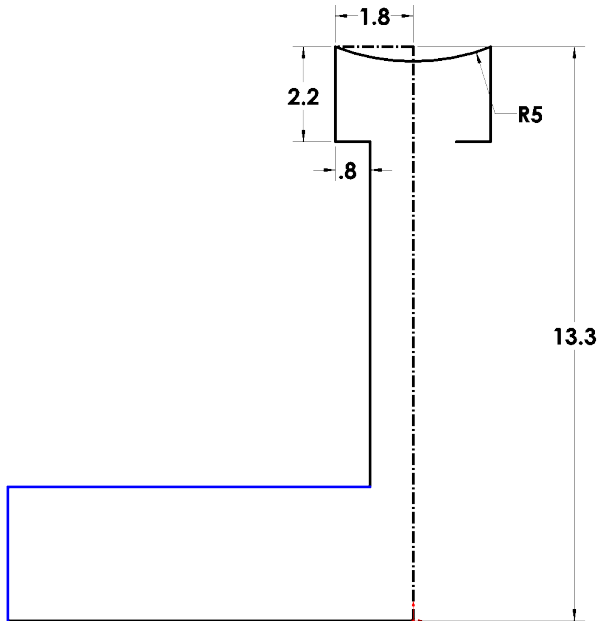

Fig. 9

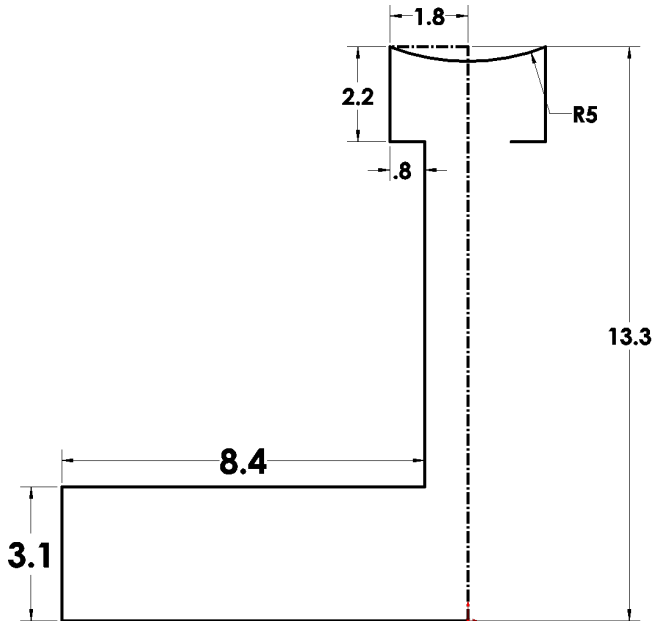

Fig. 10

G. Lines Outside Rim.

Step 1. Click **Line**  (L) on the Sketch toolbar.

Step 2. Sketch the **6 lines**, **Fig. 11**.

Step 3. Click **Smart Dimension**  (S) on the Sketch toolbar.

Step 4. Add dimensions, **Fig. 12**.

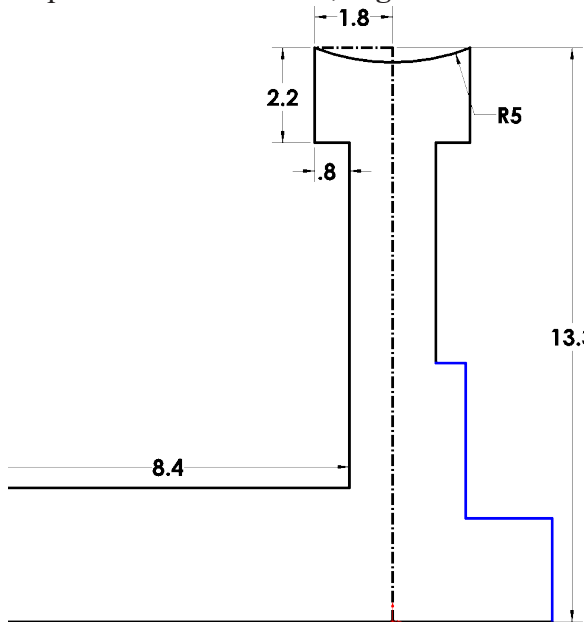

Fig. 11

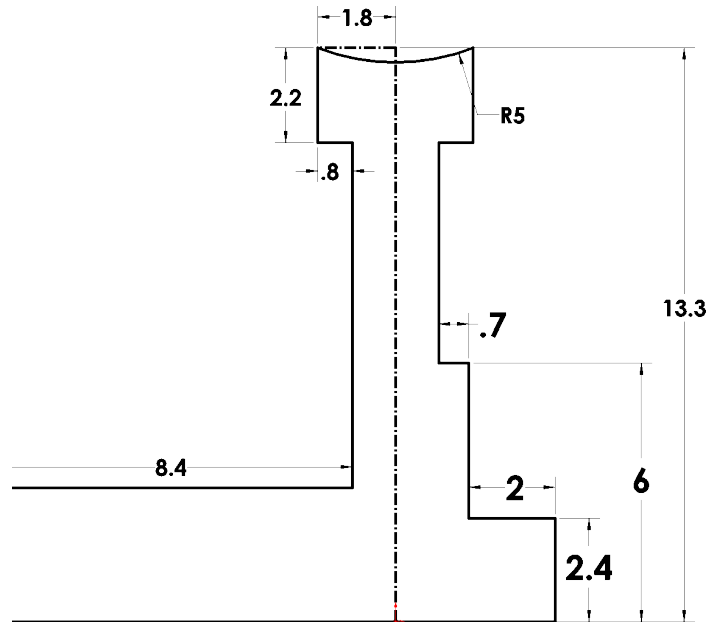



Fig. 12

H. Revolved Boss/Base.

Step 1. Click **Features**  on the Command Manager toolbar.

Step 2. Click **Revolved Boss/Base**  on the Features toolbar.

Step 3. In the Revolve Property Manger:

under Axis of Revolution

click **bottom line of sketch**, **Fig. 14**.

Your bottom line of sketch does not have to show in Property Manager as Line10.

Click OK .

Step 4. Save  (Ctrl-S).

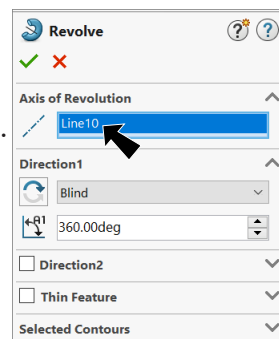

Fig. 13

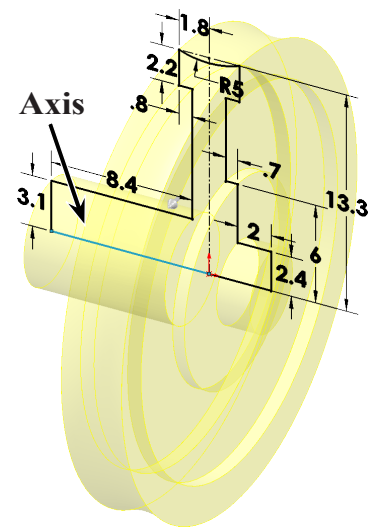



Fig. 14

I. Hole for Axle.

Step 1. Rotate view slightly to view **inside of rim (back side)**, hold down middle mouse button (wheel) and drag to rotate view, **Fig. 15**.

Step 2. Click **inside face of hub** and click **Sketch**  on the context toolbar, **Fig. 15**.

Step 3. Click **Circle**  (S) on the Sketch toolbar.



Step 4. Sketch a circle for hole starting at the Origin , **Fig. 16**.

Step 5. Click **Smart Dimension**  (S) on the Sketch toolbar.

Step 6. Dimension **diameter 3.5**, **Fig. 16**.

Step 7. Click **Features**  on the Command Manager toolbar.

Step 8. Click **Extruded Cut**  on the Features toolbar.

Step 9. In the Cut-Extrude Property Manager set:
 under Direction 1, **Fig. 17**
 End Condition **Blind**
Depth  **9**
 click OK .

Step 10. Save  (Ctrl-S).

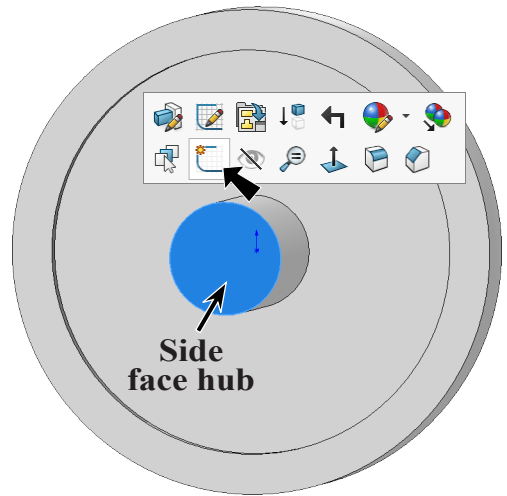

Fig. 15

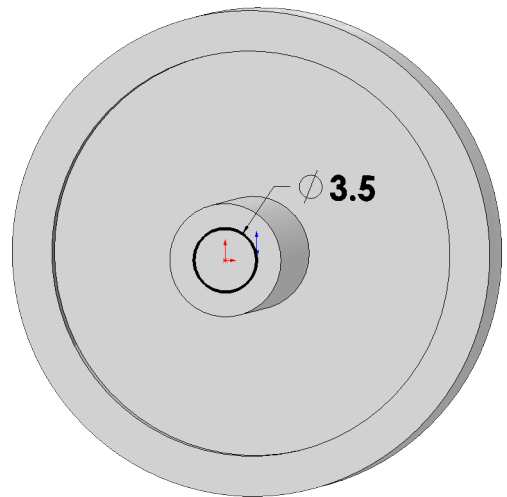

Fig. 15

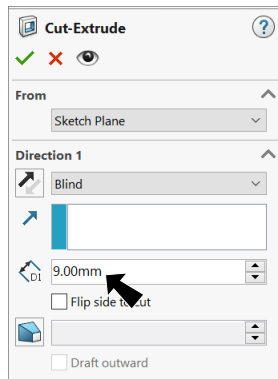

Fig. 17

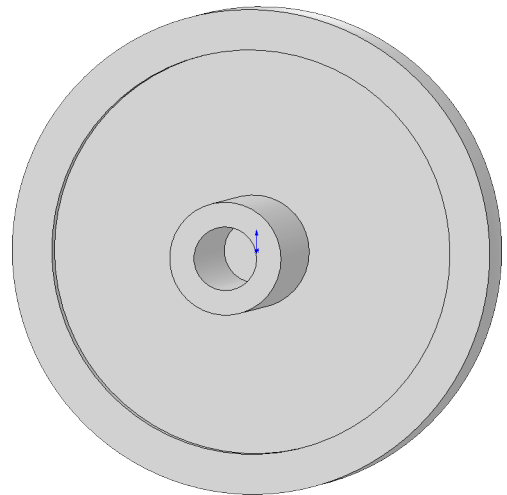



Fig. 18

J. Hole in Rim.

Step 1. Click **Isometric**  on the Standard Views toolbar. (Ctrl-7)

Step 2. Click **side face of rim** and click **Sketch**  on the context toolbar, Fig. 19.

Step 3. Click **Normal To**  on the Standard Views toolbar.



Step 4. Click **Circle**  (S) on the Sketch toolbar.

Step 5. Sketch a circle for the hole above the Origin , Fig. 20.

Step 6. Click **Smart Dimension**  (S) on the Sketch toolbar.

Step 7. Add dimensions, Fig. 20.

Step 8. **Unselect Smart Dimension.** To unselect, **right click graphics area and click Select**  from menu.

Step 9. **Ctrl click centerpoint of circle and Origin**  to select both. Release Ctrl key and click **Make Vertical**  on the context toolbar, Fig. 21.

Step 10. Click **Isometric**  on the Standard Views toolbar. (Ctrl-7)

Step 11. Click **Features**  on the Command Manager toolbar.

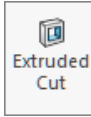
Step 12. Click **Extruded Cut**  on the Features toolbar.

Step 13. In Cut-Extrude Property Manager:
under Direction1, Fig. 22
End Condition **Through All**
click OK .

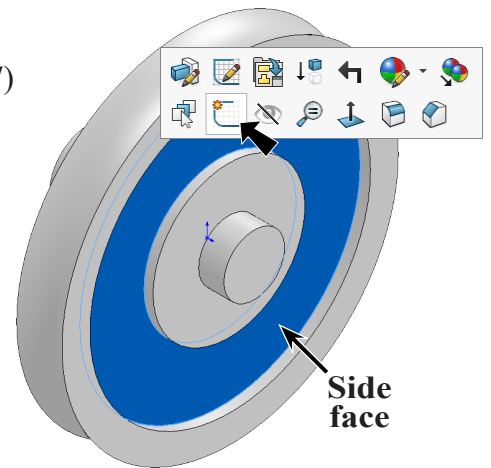

Fig. 19

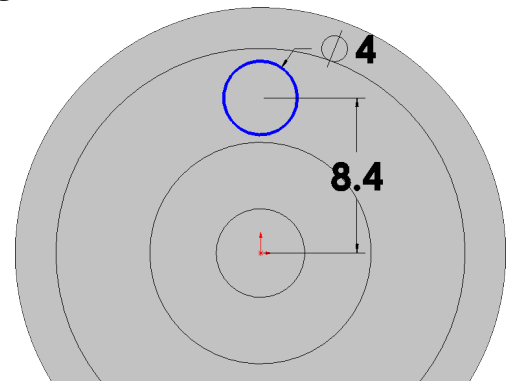

Fig. 20

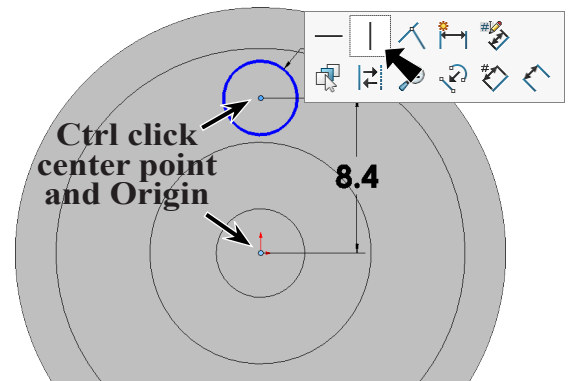

Fig. 21

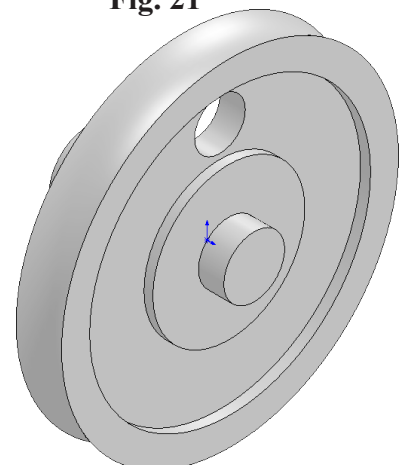

Fig. 23

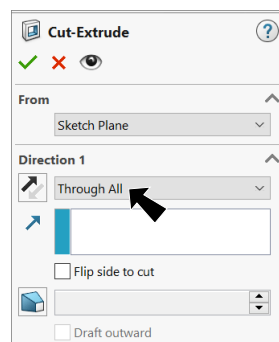





Fig. 22

K. Circular Pattern for Hole.

Step 1. Click **Circular Pattern**  **Circular Pattern** in the **Linear Pattern** flyout  on the Features toolbar.

Step 2. In the Circular Pattern Property Manager set:
 under Features and Faces, **Fig. 24**
 click **hole feature in Rim**, **Fig. 25**
 under Direction 1
 click in **Pattern Axis** box
 click **cylindrical face of hub**
 select **Equal spacing**
Number of Instances  **8**
 click OK .

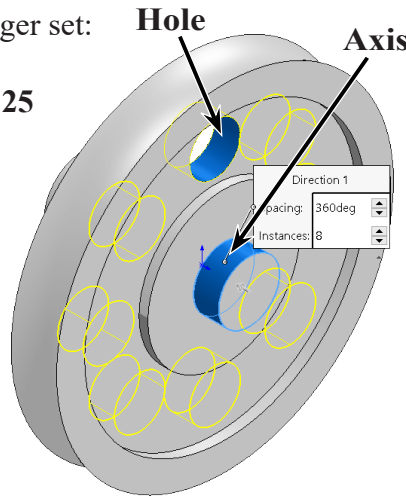

Fig. 25

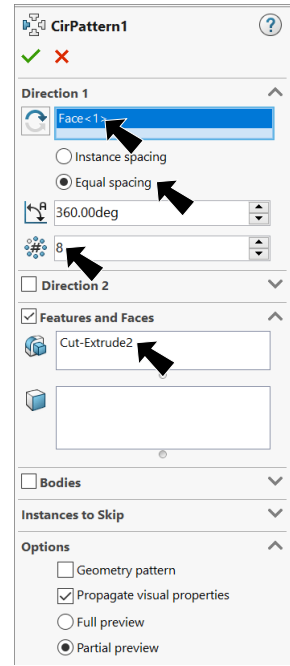



Fig. 24

Step 3. Save  (Ctrl-S).

L. Bolt.

Step 1. Click **side face of wheel cap** and click **Sketch**  on the context toolbar, **Fig. 26**.

Step 2. Click **Normal To**  on the Standard Views toolbar.

Step 3. Click **Circle**  (S) on the Sketch toolbar.

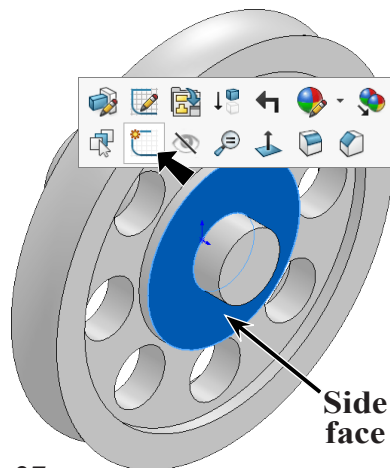



Fig. 26

Step 4. Sketch a circle above Origin , **Fig. 27**.

Step 5. Click **Smart Dimension**  (S) on the Sketch toolbar.

Step 6. Add dimensions, **Fig. 27**.

Step 7. **Unselect Smart Dimension**. To unselect, **right click graphics area and click Select**  from menu.

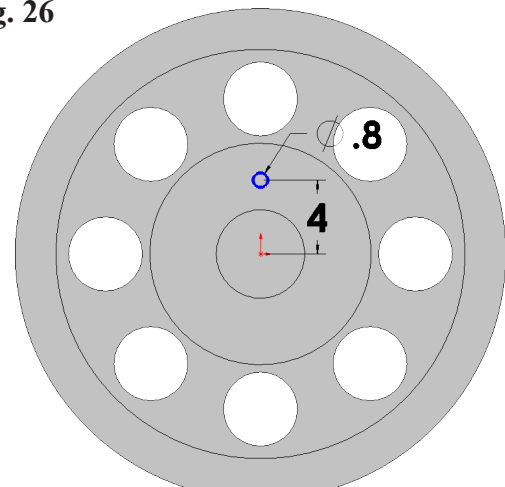

Fig. 27

Step 8. **Ctrl click centerpoint of circle and Origin** to select both. Release Ctrl key and click **Make Vertical** on the context toolbar, Fig. 28.

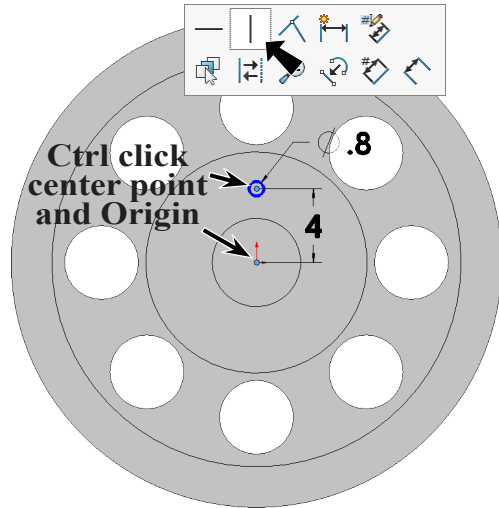

Fig. 28

Step 9. Click **Isometric** on the Standard Views toolbar. (Ctrl-7)

Step 10. Zoom in on the **bolt circle**, Fig. 30.

Step 11. Click **Features** on the Command Manager toolbar.

Step 12. Click **Extruded Boss/Base** on the Features toolbar.

Step 13. In the Extrude Property Manager set:

Depth .2
click OK

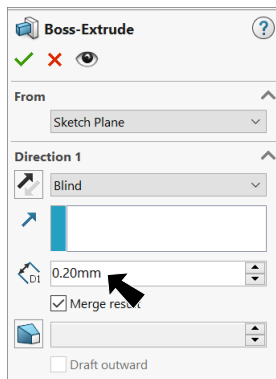

Fig. 29

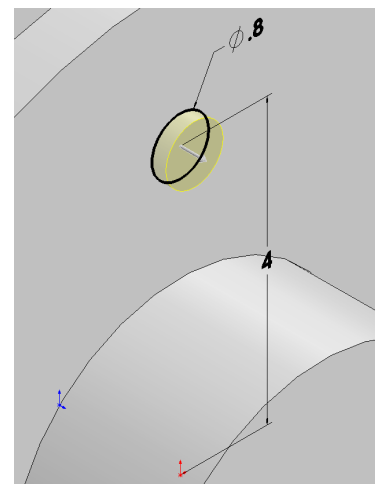

Fig. 30

Step 14. Save (Ctrl-S).

M. Dome Top Face of Bolt.

Step 1. Click **Dome** on the Features toolbar (click Insert Menu > Features > Dome).

Step 2. In the Dome Property Manager set:

under Parameters, Fig. 31
click **top face of extruded boss**,
Fig. 32
Distance .2
click OK

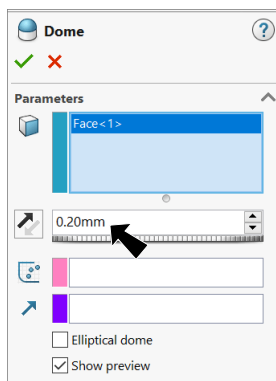

Fig. 31

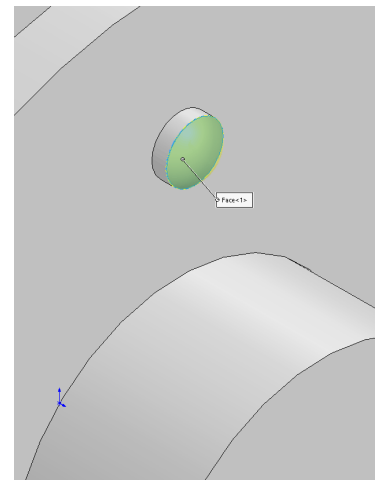

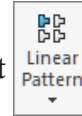

Fig. 32



Step 3. Save (Ctrl-S).

N. Circular Pattern for Bolt.

Step 1. Click **Circular Pattern**  **Circular Pattern** in the **Linear Pattern** flyout on the Features toolbar.



on the Features toolbar.

Step 2. In the Circular Pattern Property Manager set:
 under Features and Faces, **Fig. 33**
 click **Dome1** and **Extrude1**, **Fig. 34**
 under Direction 1
 click in **Pattern Axis** box
 click **cylindrical face of hub**
 select **Equal spacing**
Number of Instances  **10**
 click OK  .

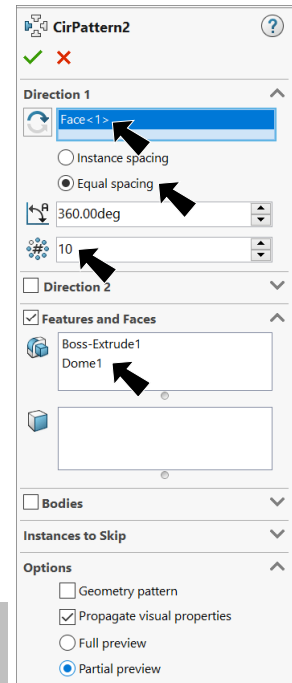

Fig. 33

Step 3. Save  (Ctrl-S).

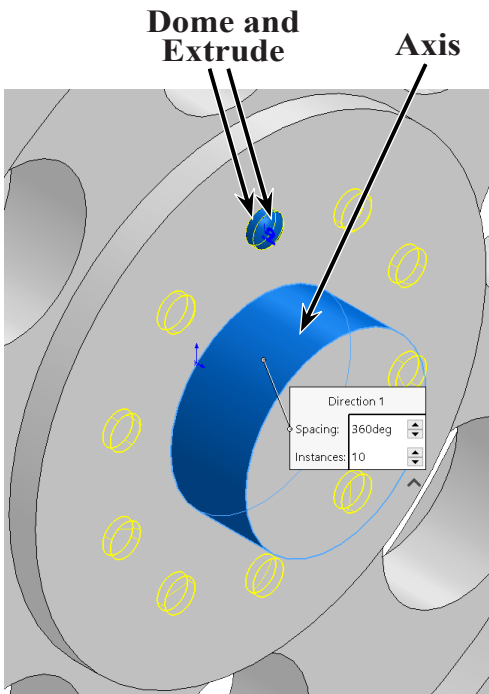

Fig. 34

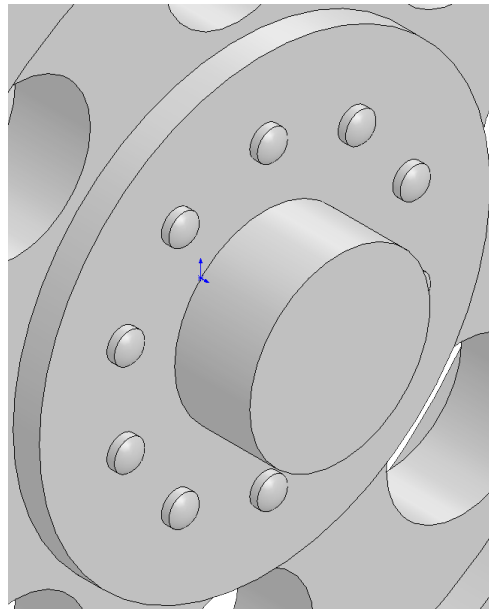

Fig. 35

O. Fillet Edges of Rim.

Step 1. Click **Fillet**  on the Features toolbar.

Step 2. In the Fillet Property Manager set:
select **FilletXpert**, **Fig. 36**
set **Radius**  **.5**
click **4 edges of rim**, **Fig. 37**
click **OK** .

Step 3. Save  (**Ctrl-S**).

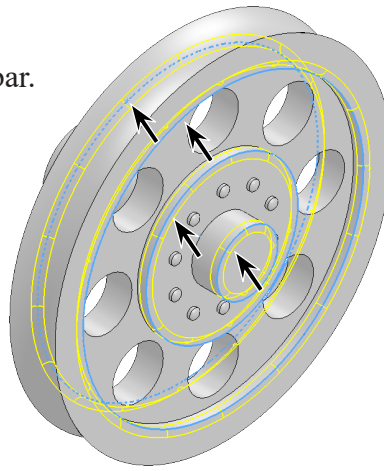

Fig. 37

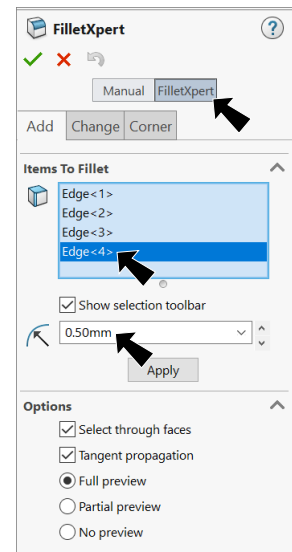



Fig. 36

P. Material Chrome Stainless Steel.

Step 1. Right click **Material**  in the Feature Manager and click **Edit Material**, **Fig. 38**.

Step 2. Expand **Steel** in the material tree and select **Chrome Stainless Steel**. Click **Apply** and **Close**.

Step 3. Save  (**Ctrl-S**).



Fig. 39

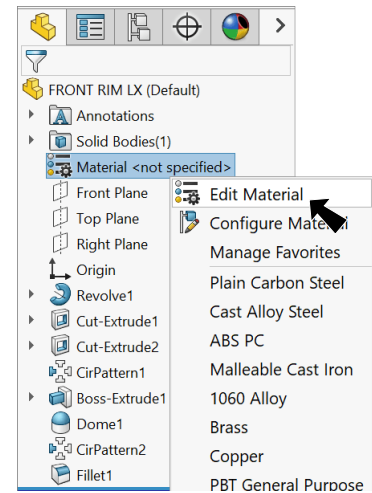

Fig. 38