





CO₂ Rail Car Front Tire



A. Sketch Construction Lines.

- Step 1. Click File Menu > New, click **Part Metric** and OK.
- Step 2. Click **Front Plane**  in the Feature Manager and click **Sketch**  on the context toolbar, **Fig. 1**.
- Step 3. Click **Centerline**  in the **Line flyout**  on the Sketch toolbar.
- Step 4. Starting at the Origin  sketch a vertical centerline up from the Origin and a horizontal centerline out to left from Origin, **Fig. 2**. To terminate chain, double click after sketching line.

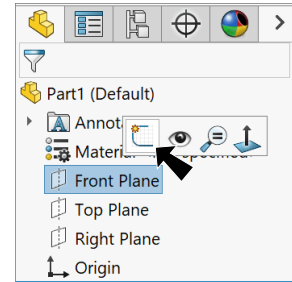



Fig. 1

- Step 5. Click **Smart Dimension**  (S) on the Sketch toolbar.
- Step 6. Dimension the vertical centerline **17**, **Fig. 2**.

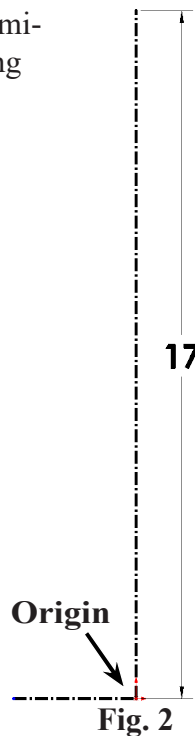

Fig. 2

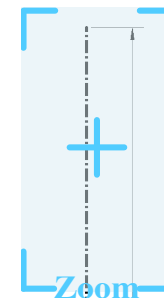



Fig. 3

B. Save as "FRONT TIRE".

- Step 1. Click File Menu > Save As.
- Step 2. Key-in **FRONT TIRE** for the filename and press ENTER.

C. 3 Point Arc.

- Step 1. Zoom in at **top of vertical centerline**, **Fig. 3**.
- Step 2. Click **3 Point Arc**  (S) in the **Arc flyout**  on the Sketch toolbar.
- Step 3. Sketch an arc between the Position 1, Position 2 and Position 3 in **Fig. 4**. To sketch the arc, first click Position 1, then Position 2. Swing the arc out to Position 3 and click.

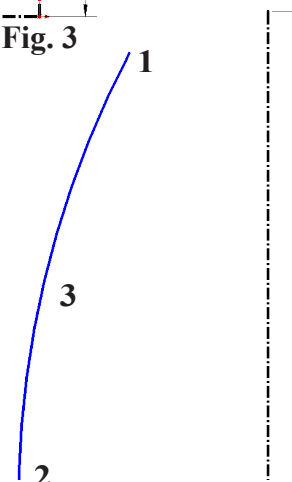

Fig. 4

Step 4. Click **Smart Dimension**  (S) on the Sketch toolbar.

Step 5. Add dimension. Dimension the arc radius 7 last and 3.7 to top endpoint of centerline, **Fig. 5**.

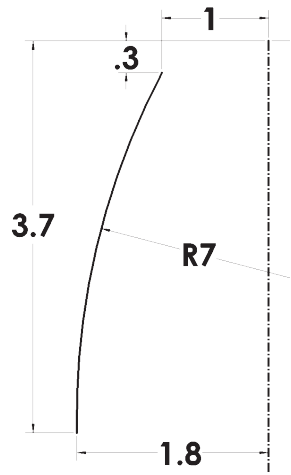

Fig. 5

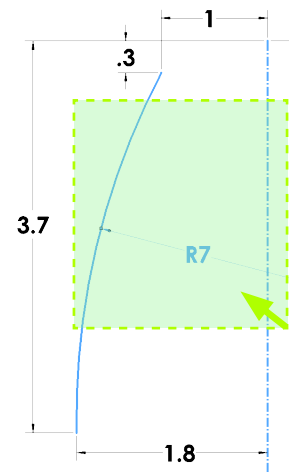

Fig. 6

D. Mirror Sketch.

Step 1. **Unselect Smart Dimension.** To unselect, **right click graphics area and click Select**  from menu.

Step 2. **Drag a selection to left across arc and vertical centerline, Fig. 6.**

Step 3. Click **Mirror Entities**  on the Sketch toolbar, **Fig. 7**.

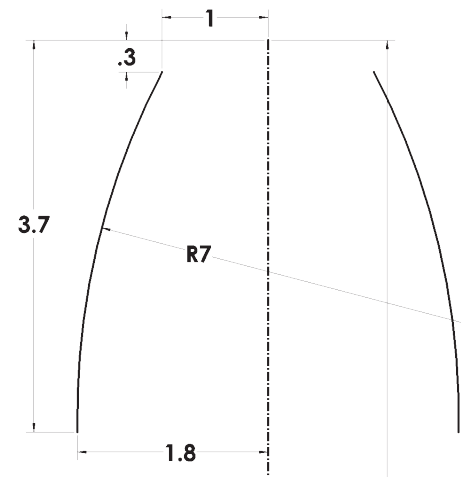



Fig. 7

E. 3 Point Arcs.

Step 1. Click **3 Point Arc**  (S) in the **Arc flyout**  on the Sketch toolbar.

Step 2. Sketch an arc across top endpoints of arcs and a second arc across bottom endpoints of arcs, **Fig. 8**.

Step 3. **Unselect Arc Tool.** To unselect, **right click graphics area and click Select**  from menu.

Step 4. **Ctrl click top arc and top endpoint of vertical centerline** to select both. Release Ctrl key and click **Make Coincident**  on the context toolbar, **Fig. 9**.

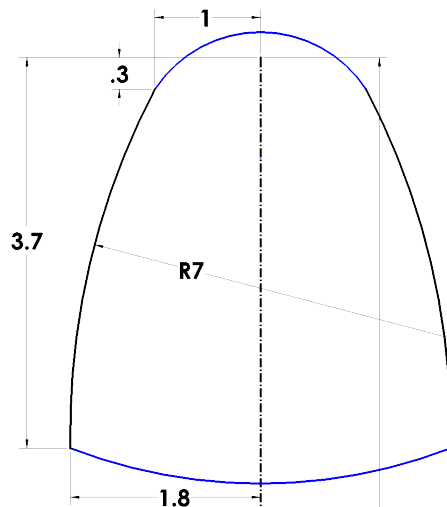

Fig. 8

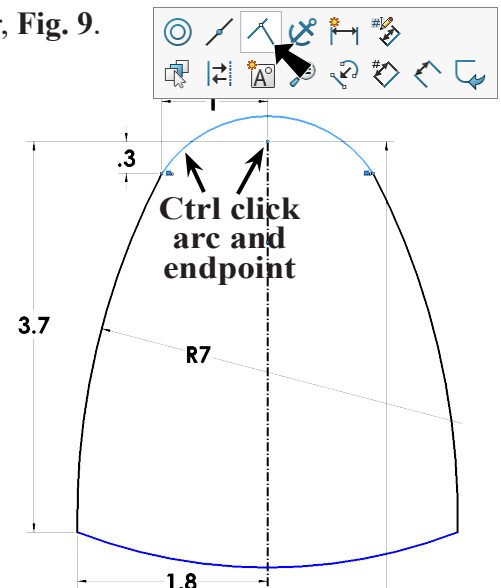

Fig. 9

Step 5. Click **Smart Dimension**  (S) on the Sketch toolbar.

Step 6. Dimension bottom arc radius 5, Fig. 10.

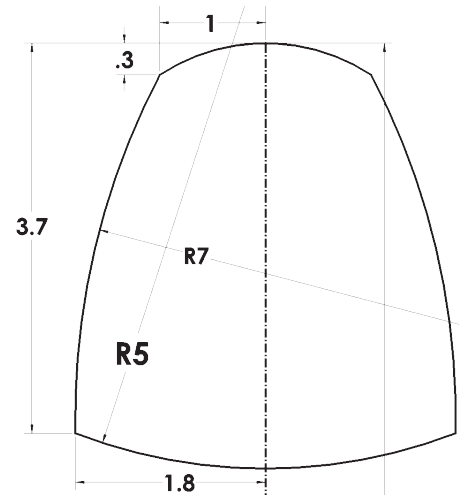



Fig. 10

F. Revolved Boss/Base.

Step 1. Click **Features**  on the Command Manager toolbar.

Step 2. Click **Revolved Boss/Base**  on the Features toolbar.

Step 3. In the Revolve Property Manger:
 under Axis of Revolution 
 click **horizontal construction line**,
Fig. 12
 click OK .

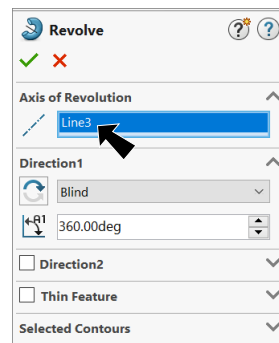

Fig. 11

Step 4. Save  (Ctrl-S).

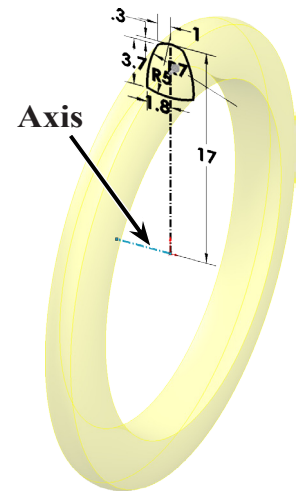



Fig. 12

G. Material Rubber.

Step 1. **Right click** **Material**  in the Feature Manager and click **Edit Material**,
Fig. 13.

Step 2. Expand **Rubber** in the material tree and select **EPDM 60 Durometer**.
 Click **Apply** and **Close**.

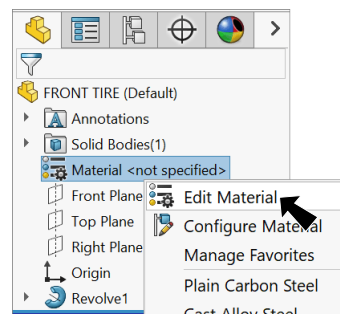

Fig. 13

Step 3. Save  (Ctrl-S).

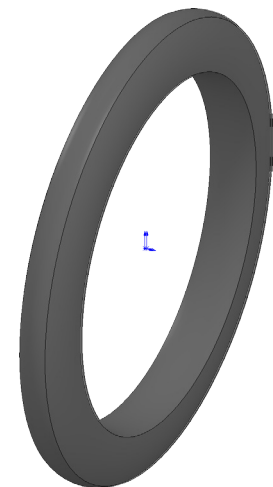

Fig. 14