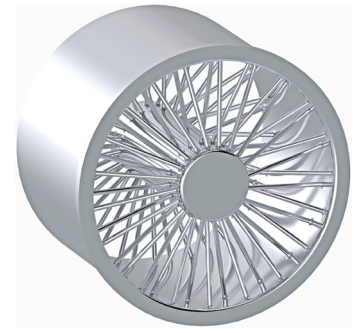




# CO<sub>2</sub> Rail Car Rear Rim Spokes



## A. Sketch Hub.

- Step 1. Click File Menu > New, click **Part Metric** and OK.
- Step 2. Click **Front Plane**  in the Feature Manager and click **Sketch**  on the context toolbar, **Fig. 1**.

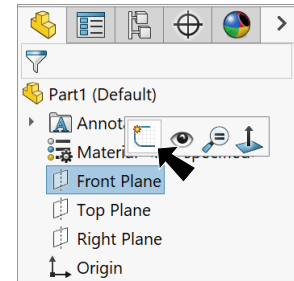





Fig. 1

- Step 3. Click **Corner Rectangle**  in the **Rectangle flyout**  on the Sketch toolbar.

- Step 4. Sketch a rectangle starting at the Origin , **Fig. 2**.

- Step 5. Click **Smart Dimension**  (S) on the Sketch toolbar.

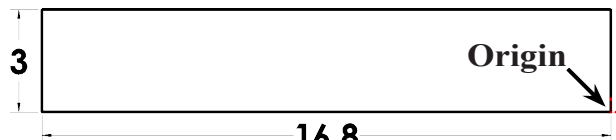


Fig. 2

- Step 6. Add dimensions, **Fig. 2**.

## B. Save as "REAR RIM SPOKES".

- Step 1. Click File Menu > Save As.
- Step 2. Key-in **REAR RIM SPOKES** for the filename and press ENTER.



## C. Sketch Rim.

- Step 1. Click **Line**  (L) on the Sketch toolbar.

- Step 2. Sketch the lines above rectangle, **Fig. 3**. Use the inferencing line, the dotted line that appears when you sketch to keep lines vertical or horizontal.

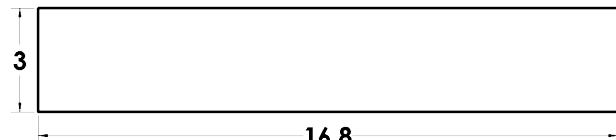

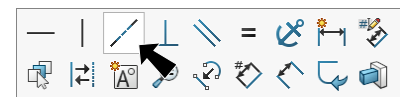



Fig. 3

- Step 3. **Unselect Line tool.** To unselect, **right click graphics area and click Select**  from menu.



- Step 4. **Ctrl click the right line of the rectangle and the right vertical line** to select both. Release Ctrl key and click **Make Collinear**  on the context toolbar, **Fig. 4**.

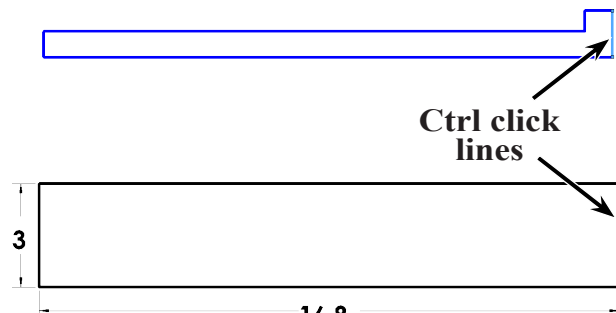
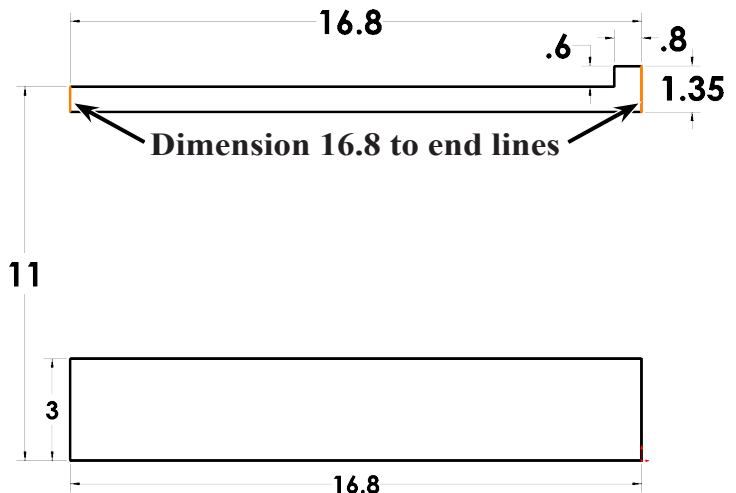


Fig. 4

Step 5. Click **Smart Dimension** (S) on the Sketch toolbar.



Step 6. Add dimensions, **Fig. 5**. Dimension the 16.8 at the rim to the **end lines** and not to the endpoints.

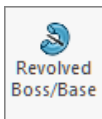


**Fig. 5**

### D. Revolved Rim.

Step 1. Click **Features** **Features** on the Command Manager toolbar.

Step 2. Click **Revolved Boss/Base**

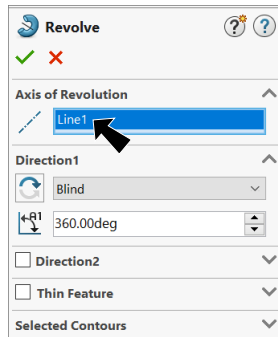


on the Features toolbar.

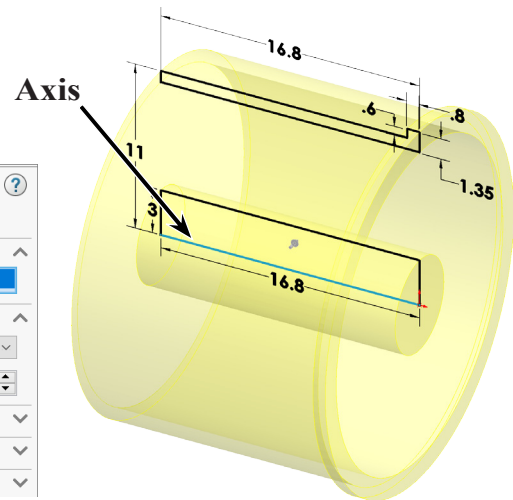
Step 3. In the Revolve Property Manger set:

- under Axis of Revolution
- click **bottom line of sketch**, **Fig. 7**
- click OK ✓.

Step 4. Save (Ctrl-S).




**Fig. 6**




**Fig. 7**

## E. Hole for Axle.

Step 1. Rotate view slightly to view **inside of rim**, hold down middle mouse button (wheel) and drag to rotate view, **Fig. 8**.


Step 2. Click **inside face of hub** and click **Sketch**  on the context toolbar, **Fig. 8**.

Step 3. Click **Circle**  (S) on the Sketch toolbar.

Step 4. Sketch a circle for the hole starting at Origin , **Fig. 9**.

Step 5. Click **Smart Dimension**  (S) on the Sketch toolbar.

Step 6. Dimension **diameter 3.5**, **Fig. 9**.

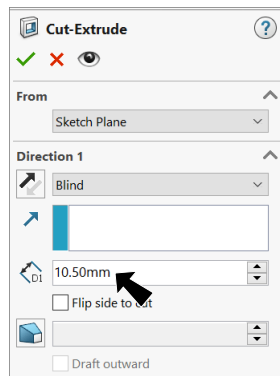
Step 7. Click **Features**  on the Command Manager toolbar.

Step 8. Click **Extruded Cut**  on the Features toolbar.

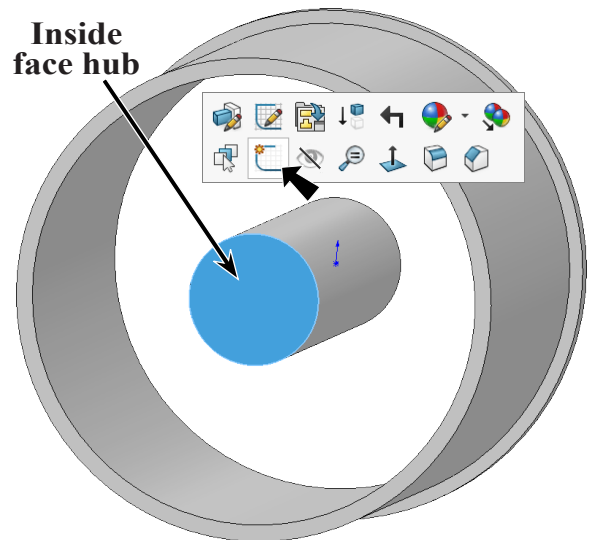
Step 9. In the Cut-Extrude Property Manager set: under Direction 1, **Fig. 10**

**Depth**  **10.5**  
click OK .

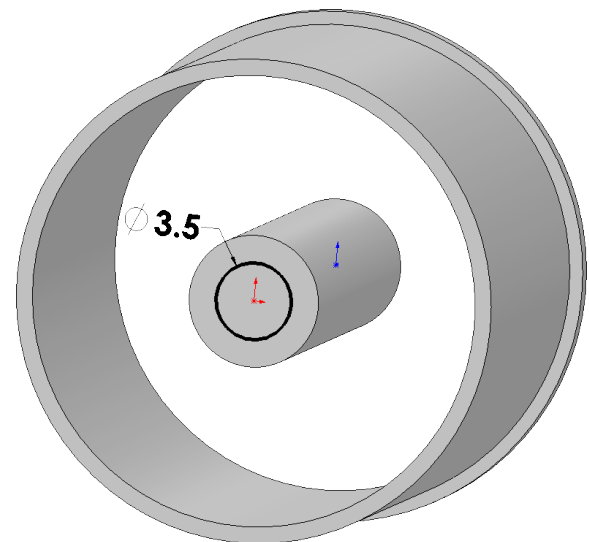
Step 10. Save  (Ctrl-S).



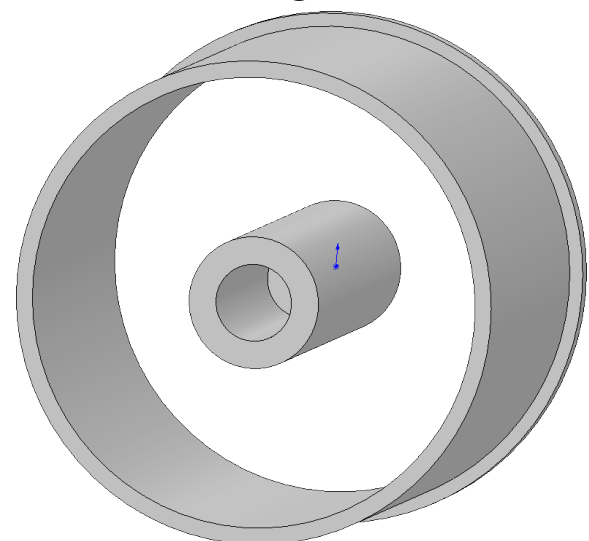
**Fig. 10**



**Fig. 8**




**Fig. 9**



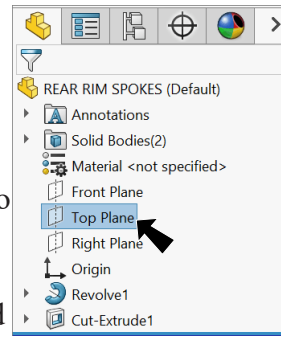
**Fig. 11**

## F. Create Plane 1 and Plane 2.

Step 1. Click **Right**  on the Standard Views toolbar. (Ctrl-4)

Step 2. Click **Top Plane**  in the Feature Manager to display plane in graphics area, **Fig. 12**.

Step 3. In graphics area **Ctrl drag Top plane up** and release, **Fig. 13**.






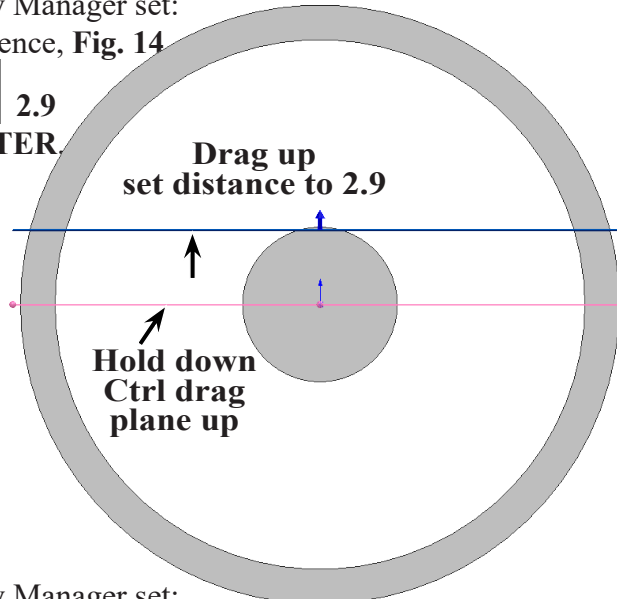
**Fig. 12**

Step 4. In the Plane Property Manager set: under First Reference, **Fig. 14**

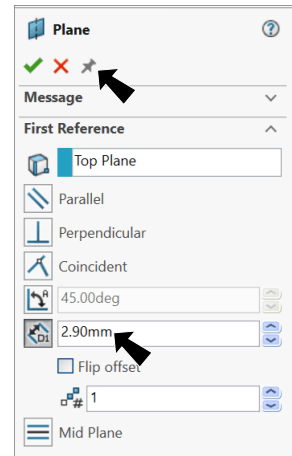
**Distance**  **2.9** and press **ENTER**.

The new plane should be to **above Top plane**, **Fig. 13**. Click **Keep Visible**

 and **OK** . The Push Pin  on allows creating another Plane.



**Fig. 13**



**Fig. 14**

Step 5. In the Plane Property Manager set: under First Reference, **Fig. 15**

click in First Reference box

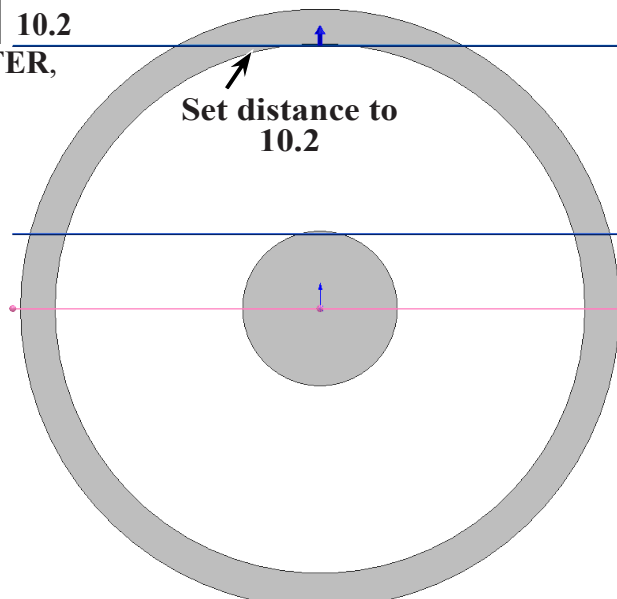
expand the flyout Feature Manager design tree (click ) in the top left corner of the graphics area and click **Top Plane** , **Fig. 16**.

**Distance**  **10.2** and press **ENTER**,

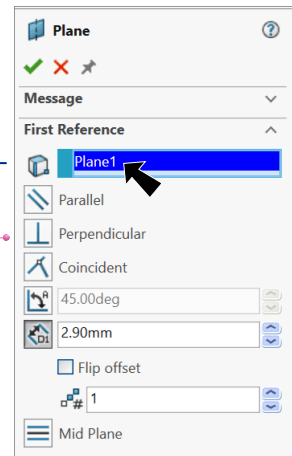
**Fig. 17**.

The new plane should be **above**, **Fig. 18**.

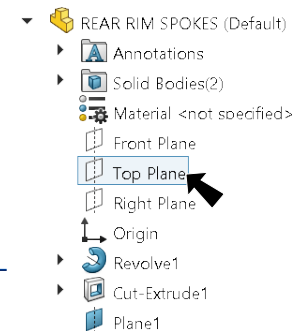
Click **OK**  and click **Cancel** .



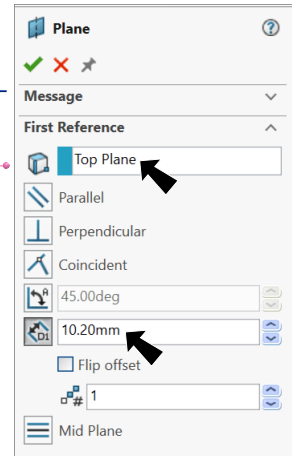
**Fig. 18**



**Fig. 15**



**Fig. 16**



**Fig. 17**

Step 6. Save  (Ctrl-S).

## G. Sketch3 in Plane1 Spoke Loft.

Step 1. **Hide Planes.** Click View Menu > Hide/Show > Planes, to hide Plane (Alt-V then H P press ENTER).

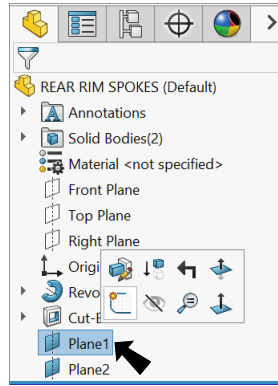


Fig. 19

Step 2. Click **Plane1** in the Feature Manager and click **Sketch** on the context toolbar, Fig. 19.

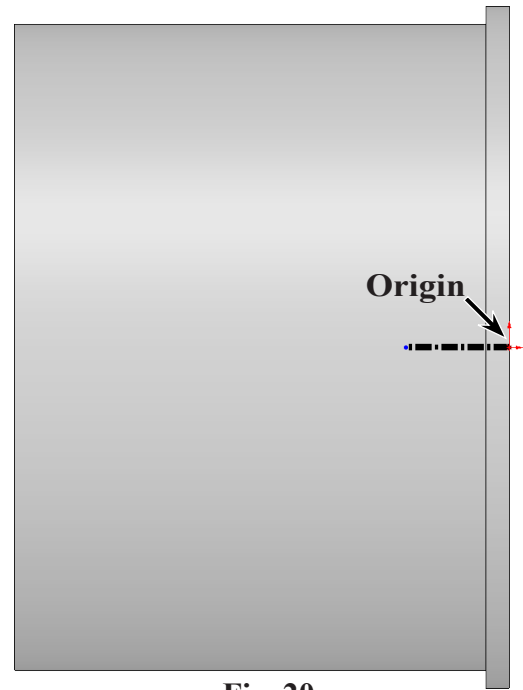


Fig. 20

Step 3. Click **Normal To** on the Standard Views toolbar. (Ctrl-8)

Step 4. Click **Centerline** in the **Line flyout** on the Sketch toolbar.

Step 5. Sketch line out to the left from Origin, Fig. 20.

Step 6. Click **Circle** (S) on the Sketch toolbar.

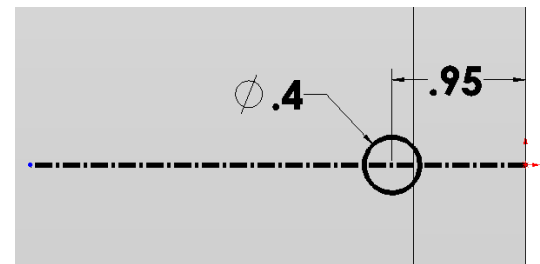


Fig. 21

Step 7. Sketch a circle on centerline, Fig. 21.

Step 8. Click **Smart Dimension** (S) on the Sketch toolbar.

Step 9. Add dimensions, Fig. 21.

Step 10. **Unselect Smart Dimension.** To unselect, **right click graphics area and click Select** from menu.

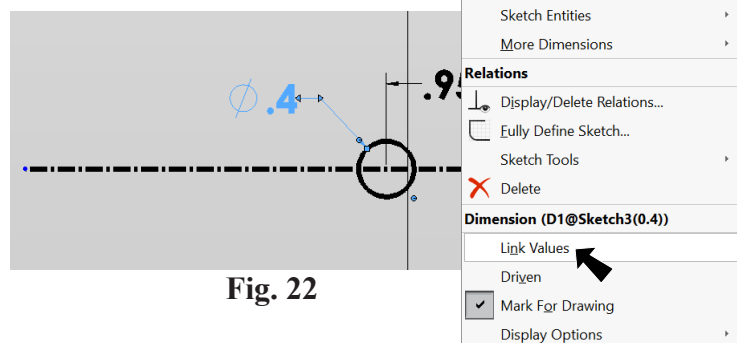


Fig. 22

Step 11. **Right click** the .4 diameter dimension and select **Link Values** from menu, Fig. 22.

Step 12. In the Shared Values dialog box key-in **Spoke Dia** for the Name and click OK, Fig. 23.

Step 13. Click **Exit Sketch**

on the Sketch toolbar.

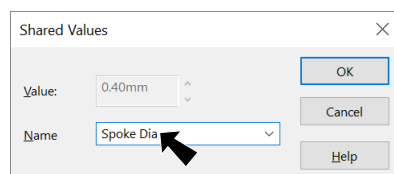


Fig. 23

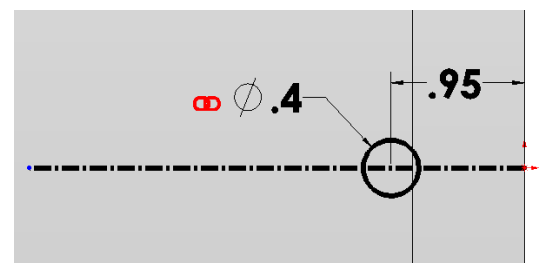
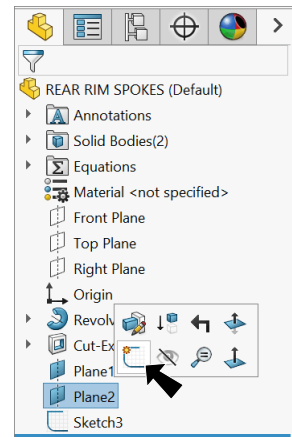


Fig. 24

## H. Sketch4 in Plane2 Spoke Loft.

Step 1. Click **Plane1**  in the Feature Manager and click **Sketch**  on the context toolbar, **Fig. 25**.



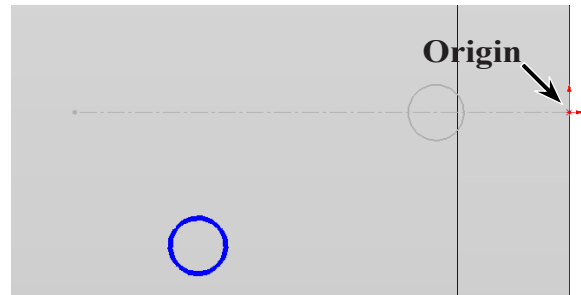
**Fig. 25**

Step 2. Click **Circle**  (S) on the Sketch toolbar.

Step 3. Sketch **circle below and to left of Origin** , **Fig. 26**.

Step 4. Click **Smart Dimension**  (S) on the Sketch toolbar.

Step 5. Add dimensions, **Fig. 27**.

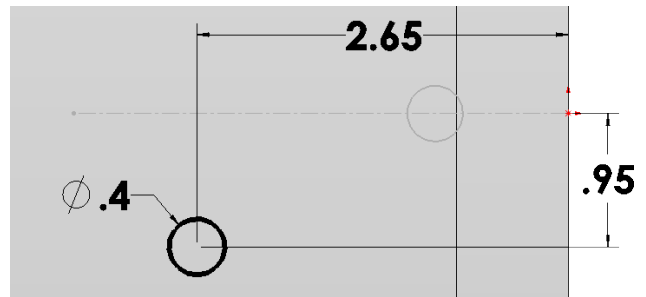


**Fig. 26**

Step 6. Unselect Smart Dimension, **right click** the **.4 diameter** dimension and select **Link Values** from menu, **Fig. 28**.

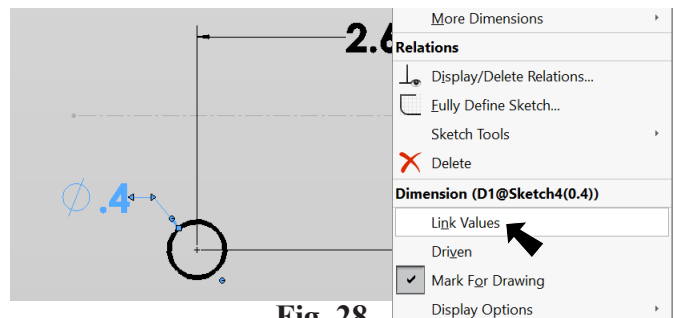
Step 7. In the Shared Values dialog box click Name drop-down arrow and select **Spoke Dia** and click OK, **Fig. 29**.

Step 8. Click **Exit Sketch**  on the Sketch toolbar.

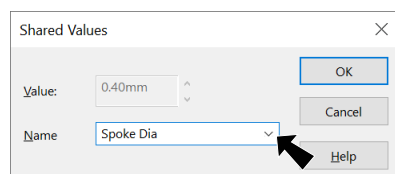


**Fig. 27**

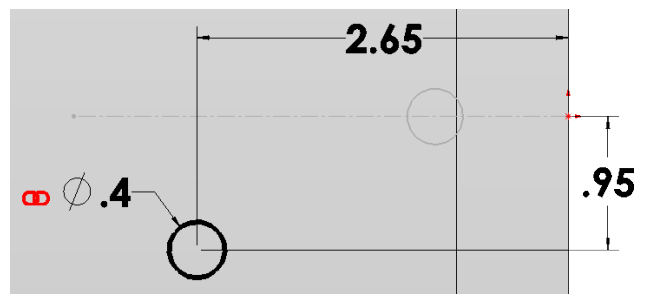
Step 9. Save  (Ctrl-S).



**Fig. 28**





**Fig. 29**



**Fig. 30**

## I. Sketch5 in Plane1 Spoke Loft.

Step 1. Click **Plane1**  in the Feature Manager and click **Sketch**  on the context toolbar, **Fig. 31**.

Step 2. Sketch **circle on the centerline that is in Sketch2**, add dimensions and add **Spoke Dia Link Value** to circle dimension, **Fig. 32**.

Step 3. Click **Exit Sketch**  on the Sketch toolbar.

Step 4. Save  (**Ctrl-S**).

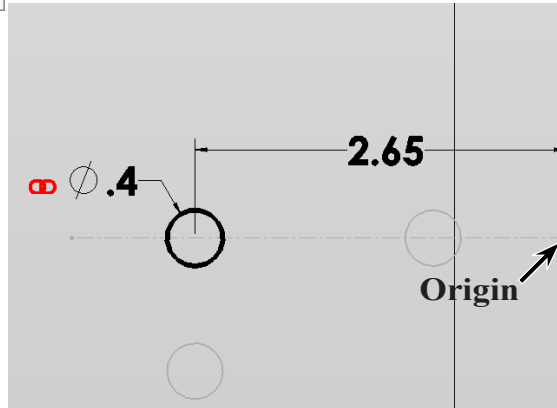


Fig. 32

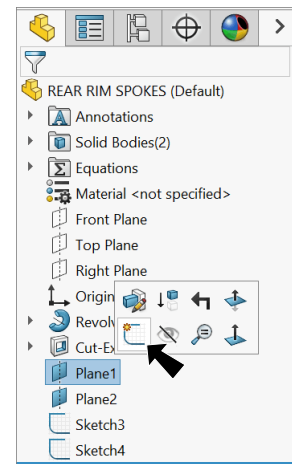


Fig. 31

## J. Sketch6 in Plane2 Spoke Loft.

Step 1. Click **Plane1**  in the Feature Manager and click **Sketch**  on the context toolbar, **Fig. 33**.

Step 2. Sketch **circle**, add dimensions and add **Spoke Dia Link Value** to circle dimension, **Fig. 34**.

Step 3. Click **Exit Sketch**  on the Sketch toolbar.

Step 4. Save  (**Ctrl-S**).

**Tip:** You can change a .4 Dia linked dimension. Rebuild (**Ctrl-R**) and all update.

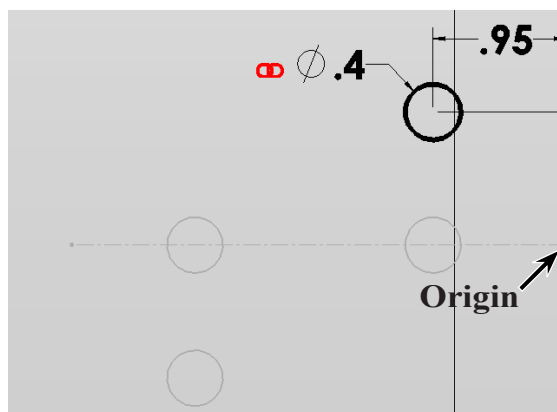


Fig. 34

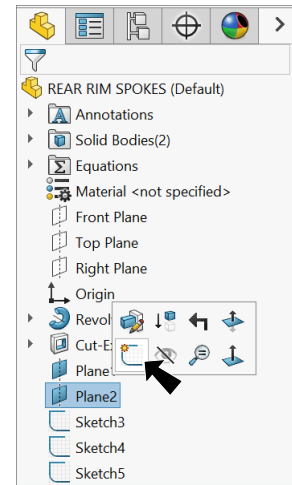


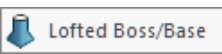


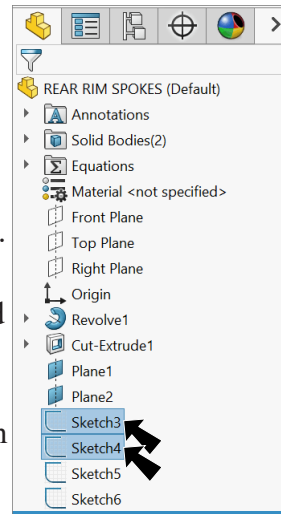


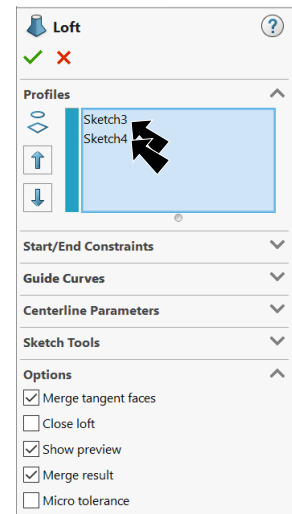
Fig. 33

## K. Loft Boss/Base 1.

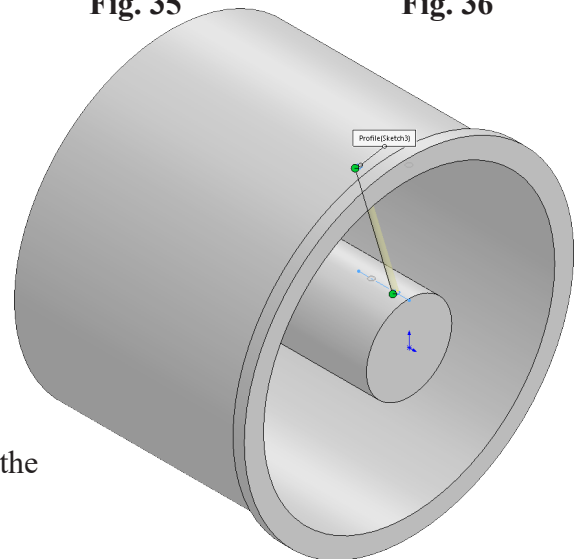
- Step 1. Click **Isometric**  on the Standard Views toolbar. (Ctrl-7)
- Step 2. **Ctrl click Sketch3 and Sketch4** in the Feature Manager to select both sketches, **Fig. 35**.
- Step 3. Click **Features**  on the Command Manager toolbar.
- Step 4. Click **Lofted Boss/Base**  on the Features toolbar.
- Step 5. In the Loft Property Manager:
  - under Profiles, **Fig. 36**
  - confirm **Sketch3 and Sketch4** selected
  - confirm the connectors  are in same position in both sketches, **Fig. 37**
  - click OK .



**Fig. 35**

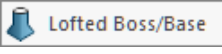




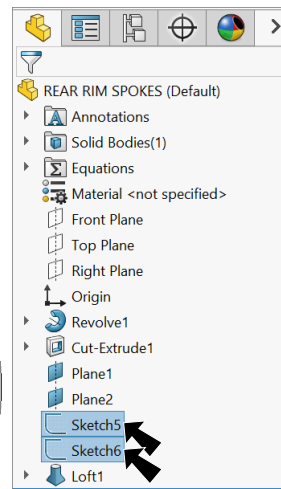
**Fig. 36**



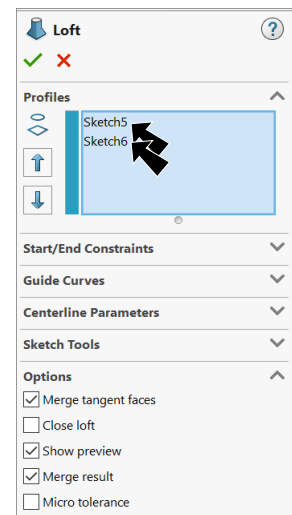
**Fig. 37**

## L. Loft Boss/Base 2.

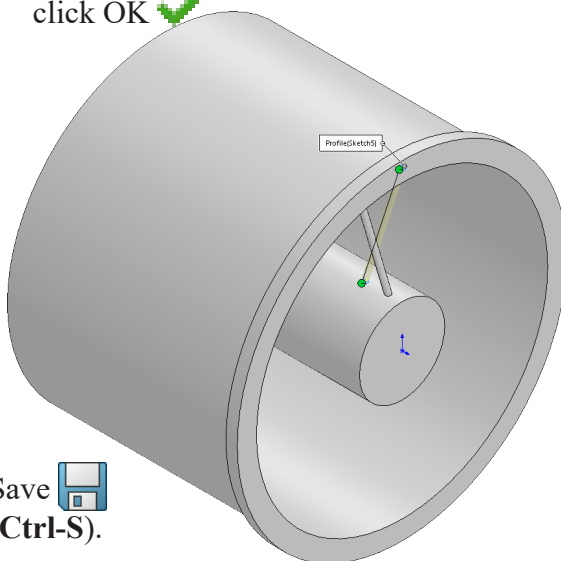
- Step 1. **Ctrl click Sketch5 and Sketch6** in the Feature Manager to select both sketches **Fig. 38**.
- Step 2. Click **Lofted Boss/Base**  on the Features toolbar.
- Step 3. In the Loft Property Manager:
  - under Profiles, **Fig. 39**
  - confirm **Sketch5 and Sketch6**
  - confirm connectors  aligned, **Fig. 40**
  - click OK .




**Fig. 38**



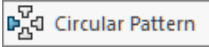

**Fig. 39**



**Fig. 40**

- Step 4. Save  (Ctrl-S).

## M. Circular Pattern Spoke.

Step 1. Click **Circular Pattern**  in the **Linear Pattern** flyout  on the Fea-

Step 2. In the Circular Pattern Property Manager set:  
 under Features and Faces, **Fig. 41**  
 click **both spokes**, **Fig. 42**  
 under Direction 1  
 click in **Pattern Axis** box  
 click **cylindrical face of hub**  
 check **Equal spacing**

Number of Instances  20

click OK .

Step 3. Save  (Ctrl-S).

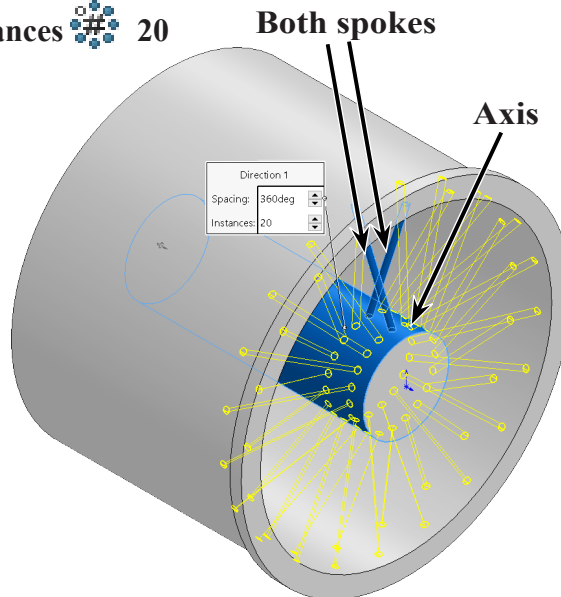


Fig. 42

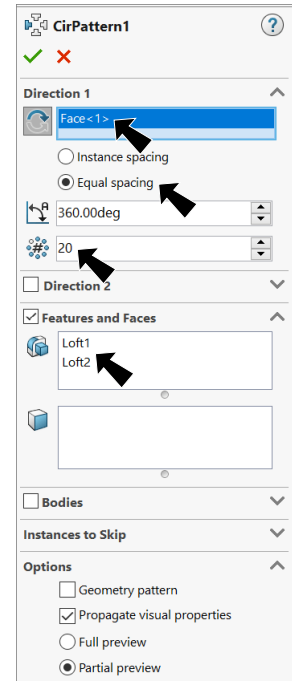


Fig. 41

## N. Fillets.

Step 1. Click **Fillet**  on the Features toolbar.

Step 2. In the Fillet Property Manager set:  
select **FilletXpert**, Fig. 43

① **Radius**  **.3**  
click **inside rear edge** and  
**two front edges**, Fig. 44

click **Apply**.

**Radius .3**

①

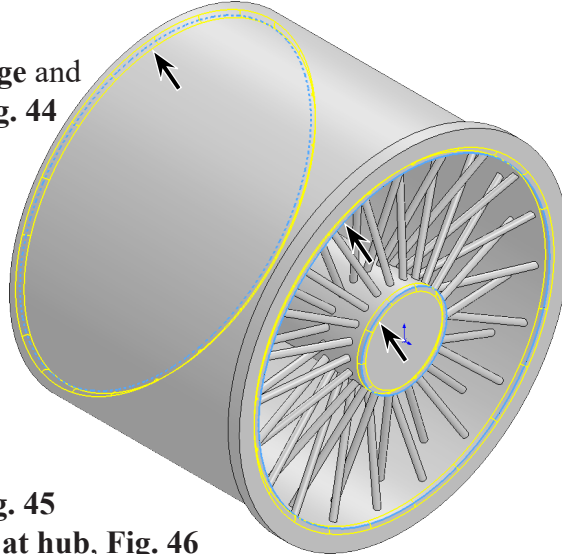


Fig. 44

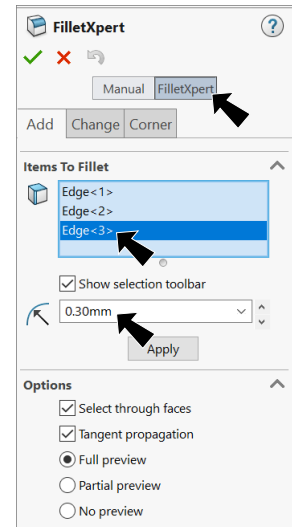


Fig. 43

Step 3. ② **Radius**  **.2**, Fig. 45  
click **edge of spoke at hub**, Fig. 46  
and click **Between right feature**

**and part, 119 Edges**   
on the Fillet pop-up  
toolbar

click **OK** .

Step 4. Save  (**Ctrl-S**).

**Radius .2**

②

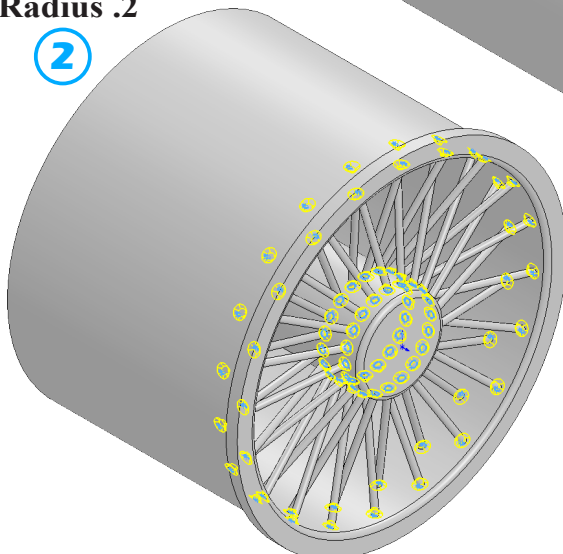


Fig. 47

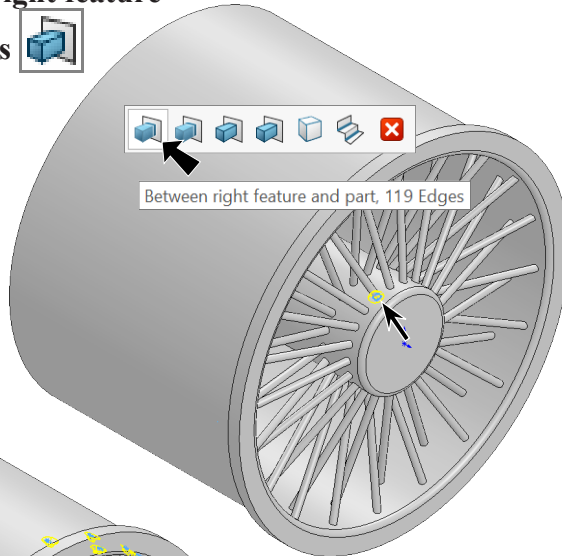


Fig. 46

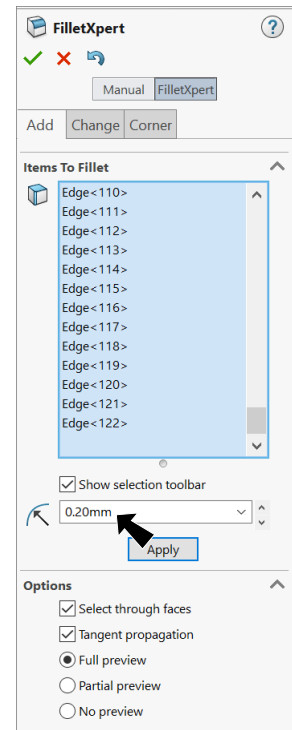
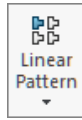


Fig. 45

## O. Linear Pattern.

Step 1. **Ctrl** click both **Lofts**, **CirPattern1** and **Fillet2** in the Feature Manager to select the features, **Fig. 48**.

Step 2. Click **Linear Pattern** on the Features toolbar.



Step 3. In the Linear Pattern Property Manager set: under Direction 1, **Fig. 49**

click in **Pattern Direction** box  
click **circular face of hub**, **Fig. 50**

**Spacing** 13

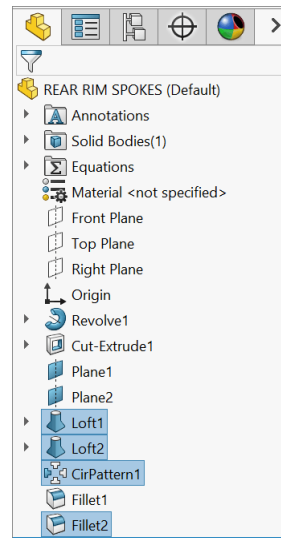
**Number of Instances** 2

Pattern should be offset inside of rim, if opposite direction

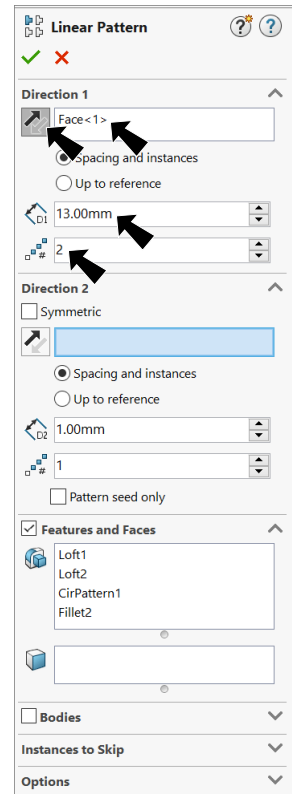
click **Reverse Direction**

click **OK** .

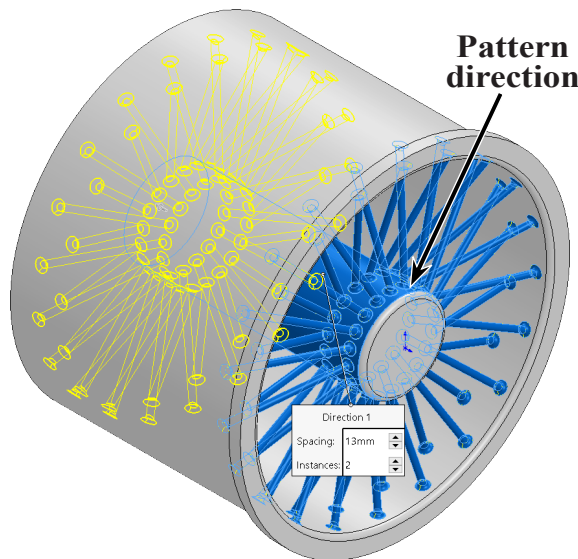
Step 4. Save (**Ctrl-S**).



**Fig. 48**




**Fig. 49**



**Fig. 50**

## P. Material Chrome Stainless Steel.

Step 1. Right click **Material**  in the Feature Manager and click **Edit Material**, Fig. 51.

Step 2. Expand **Steel** in the material tree and select **Chrome Stainless Steel**. Click **Apply** and **Close**.

Step 3. Save  (Ctrl-S).

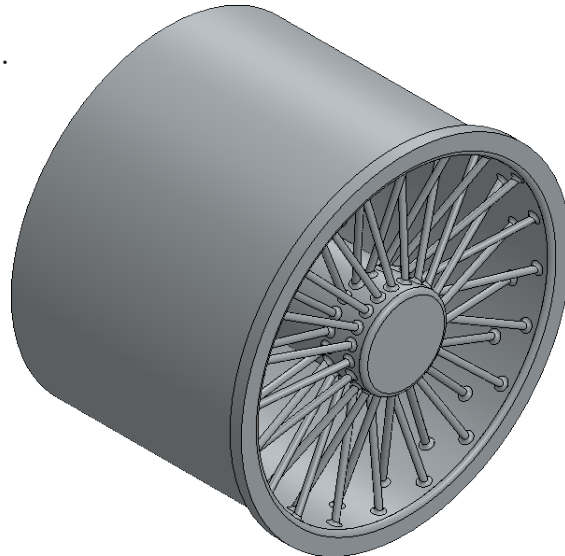


Fig. 52

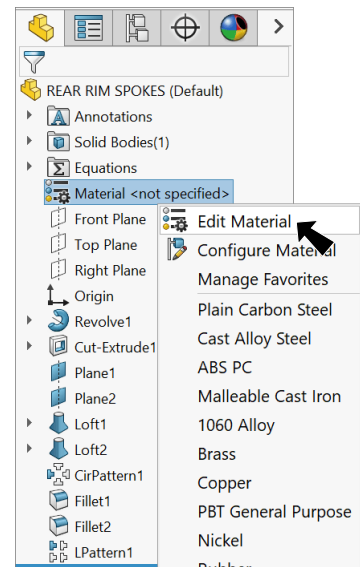


Fig. 51