

Driver Axle Assembly

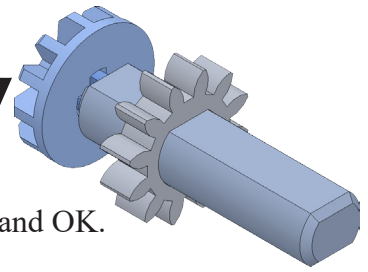

A. Insert Driver Axle, Sprocket and Bevel Gear.



Step 1. Click **New**  on the Standard toolbar, click **Assembly Metric**  and OK.

Step 2. Select your **DRIVER AXLE** file and click Open from the Open dialog box.

Step 3. In the Begin Assembly Property Manager set:

click **Keep Visible** , **Fig. 1**
under Options

Only fix first component

Click OK  in the Property Manager. This will place Axle origin at the assembly origin and fix the position so Axle cannot move. This fixed component should have a **(f)** before its name in the Feature Manager  (f) DRIVER AXLE<1>. **Fig. 2**

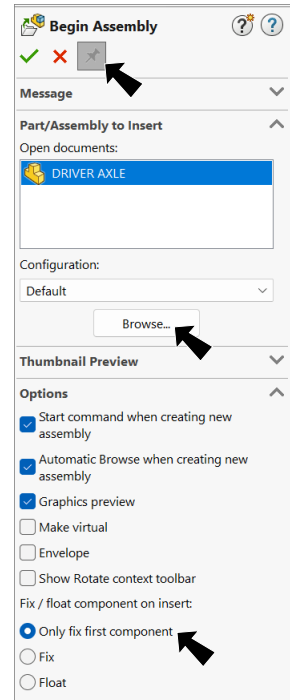
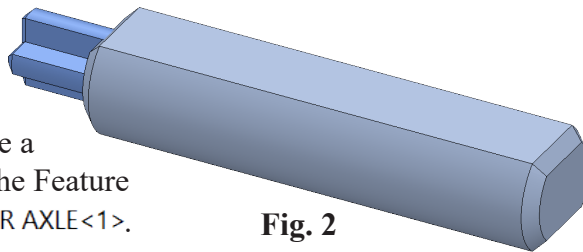
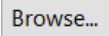



Fig. 1

Step 4. Click **Browse**  in the Property Manager, **Fig. 1**.

Step 5. **Ctrl click** your **SPROCKET** and **BEVEL GEAR** files and click Open.

Step 6. Back in the Begin Assembly Property Manager:
under Part/Assembly in Insert, **Fig. 3**
select **SPROCKET** to highlight it.

Step 7. In the graphic area position Sprocket over cylindrical face of Lego Axle in Driver Axle, **Fig. 4**. When Sprocket snaps into place and cursor changes to indicate Concentric mate , click to release Sprocket.

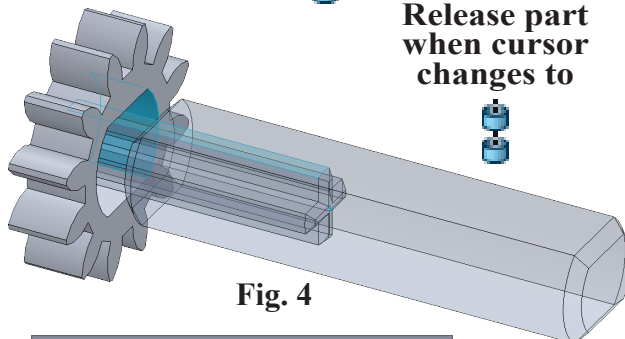

Fig. 4



Step 8. Check **Lock Rotation** and Add/
Finish Mate 
in Mate pop-up toolbar to add a
Concentric 
mate, **Fig. 5**.



Fig. 5

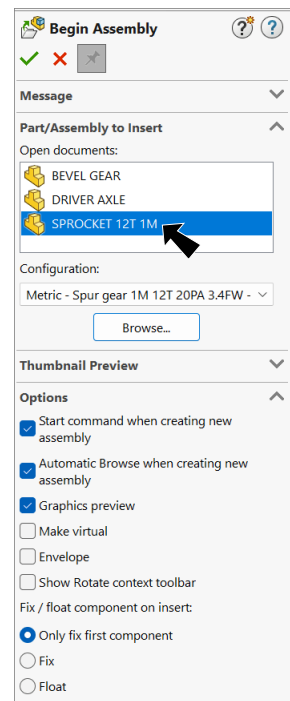

Fig. 3

Step 9. Back in Begin Assembly Property Manager:
 under Part/Assembly in Insert, **Fig. 6**
 select **BEVEL GEAR** to highlight it.

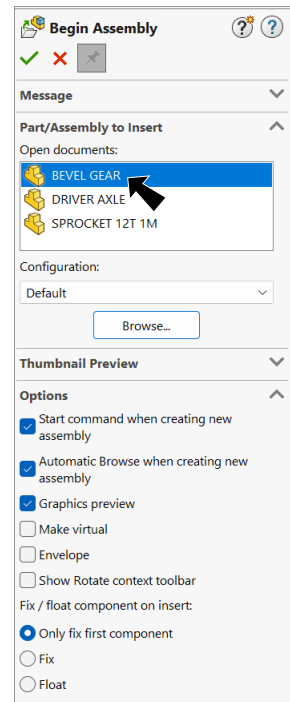



Fig. 6

Step 10. Position Bevel Gear over Driver Axle, **Fig. 7**. When Gear snaps into place and cursor changes to indicate Concentric mate , click to release Gear.

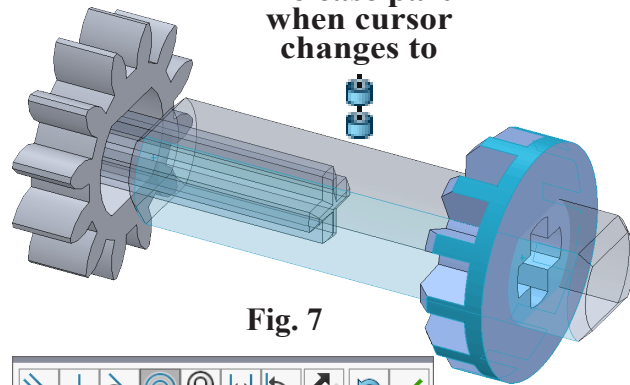

Fig. 7



Step 11. Check **Lock Rotation** and Add/Finish Mate  in Mate pop-up toolbar to add a **Concentric**  mate, **Fig. 8**.



Fig. 8

Step 12. Click OK  in the Property Manager.

B. Save as "DRIVER AXLE ASSEMBLY".

Step 1. Click File Menu > Save As.

Step 2. Key-in **DRIVER AXLE ASSEMBLY** for the filename and press ENTER.

C. Mate: Sprocket.

Step 1. Click **Right Plane**  in the Feature Manager and Mate  on the context toolbar, **Fig. 9**.

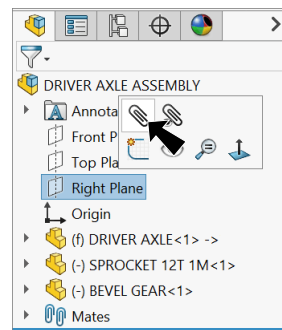



Fig. 9

Step 2. Expand the flyout Feature Manager design tree (click ) in the top left corner of the graphics area, expand **Sprocket** and click **Plane3** , **Fig. 10**.

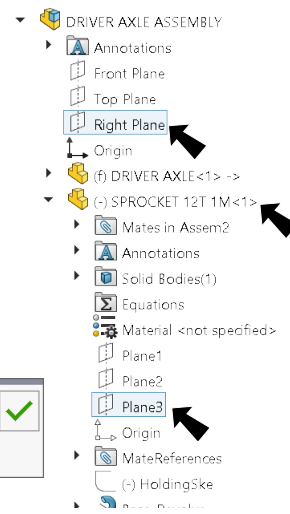

Fig. 10





Step 3. Click **Distance**  in Mate pop-up, **Fig. 11**. Set distance **20.25** and press ENTER. The Sprocket should be positioned on the Axle, **Fig. 12**. If positioned in opposite direction,



Fig. 11

click **Flip Dimension**  in the Mate pop-up. Click Add/Finish Mate  to add Distance  mate.

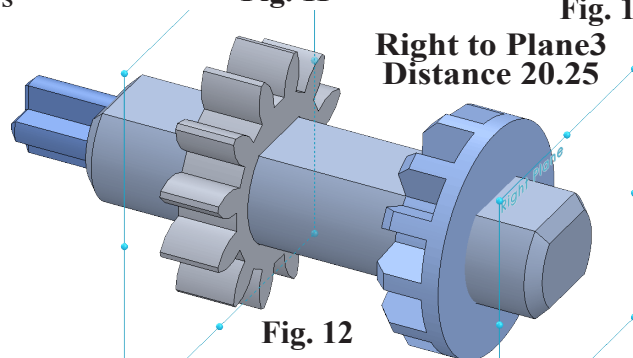
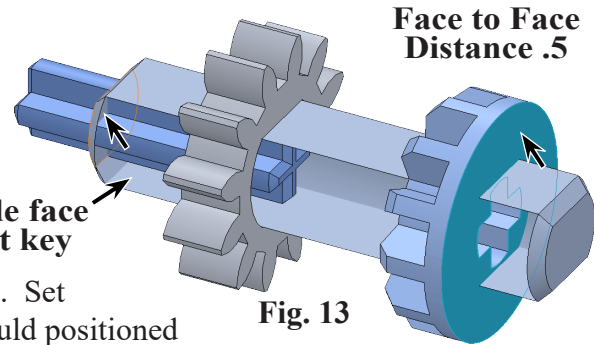





Fig. 12

D. Mate: Bevel Gear.

Step 1. Click **side face of Bevel Gear** and **hide side face of Axle**, click **flat face of end face of Axle**, Fig. 13. To hide face, hover cursor over face and press **Alt** key.



Step 2. Click **Distance**  in Mate pop-up, Fig. 14. Set **distance .5** and press ENTER. The Gear should be positioned .5 from end of Axle, Fig. 15. If positioned in opposite direction, click **Flip Dimension**  in the Mate pop-up. Click Add/Finish Mate  to add Distance  mate.



Step 3. Click OK  in the Property Manager.

Step 4. Save  (Ctrl-S).

